

MORAN

FURNITURE



Catalogue 2019/20



**A Moran Is
A Statement
In Style That
Commands
Attention.**

Content

BESPOKE The love of hand-crafting.	05
OUR STORY Celebrating the history of an iconic Melbourne brand.	07
OUR CONSTRUCTION It's what's inside that counts.	08
OUR COMFORT What does it feel like?	10
YOUR OPTIONS Customise your sofa.	14
OUR FINISHING TOUCHES Attention to detail.	18
FURNITURE CATALOGUE Our range.	20
CATALOGUE INDEX	86
OUR SERVICES Ongoing support.	88

B E S P O K E

It's fine art.

It takes a true artisan to lovingly craft the comfort and beauty into each piece of Moran furniture.

Every Moran is an individual creation, handmade for you by some of the world's finest upholstery specialists. Owning bespoke handcrafted furniture continues to be a sought after trend.

There is just no comparison between mass-produced vs. handcrafted furniture. The innovation, quality and attention to detail shine through in the way the raw materials are worked, as makers are intrinsically connected to the process of individual creation.

For decades Moran Furniture has been welcomed into homes of Australian families; many customers claiming their Moran furniture has retained its quality for so long they are a part of the family too as they are handed down from generation to generation. To this day, Moran continues on this trajectory, creating bespoke, high quality furniture to suit Australian lifestyles.

Each piece is still individually built by hand, from the inside out using the finest materials and best-practice crafts rather than mass production techniques. The specialised traditional techniques used to build Moran Furniture have been entrusted to a select number of artisans embracing Moran's best-practice standards helping to ensure these skills are able to be continued on for future generations and to meet the continued demand for handcrafted furniture worldwide.

While the corporate ethos is modern, Moran Furniture continues to uphold genuine traditional standards like quality hand-craftsmanship, long-lasting comfort and value for money, the result of which ensures every Moran furniture piece is a statement in uncompromised luxury.

Choosing handmade furniture from Moran Furniture helps support our dedicated team positioned locally and internationally to continue to deliver quality and craftsmanship with inspiring designs to create beautiful, timeless interiors.

Handcrafted to perfection.



MORAN BOSTON CHAIR
DISPLAYED IN: MORAN FABRIC & TIMBER LEGS
DAVID JONES EXCLUSIVE

O U R S T O R Y

Moran has had a rich 60 plus year history. From humble beginnings, Moran Furniture grew into what is now arguably Australia's most long-standing and recognized premium upholstered furniture manufacturer.

John Moran, the founder of the brand, pioneered many innovations both within the company and industry. All the while, he never wavered from his philosophy of delivering high quality, comfort and value. This vision has developed into a truly international business, continuing to make some of the very best furniture in the world.

When John Moran rolled out his first upholstered piece of furniture, the Michigan sofa, he probably never expected that 60 years later his name would become an iconic brand name in Australian furniture.

Today hundreds of thousands of Australians live with a Moran. In fact, Moran has produced over one million pieces of furniture.

John's great belief in his product, inspired vision and value proposition, he has shared first hand and in imparting his knowledge with others over the years, has had a profound effect on many who speak fondly of their interactions with him and his passion for the industry.

John's belief in his hand made furniture and charisma would soon make Moran Furniture what people wanted as a status symbol in their home.

In 2002 John Moran embarked on a manufacturing partnership in a state of the art facility in Shanghai. John's approach to business was innovative and his forward thinking ensured the stability of the business to maintain a quality, and value offering to Australians.

Unfortunately 2003 saw the sad passing of John Moran, but his passion and commitment to the business he built still continues to this day.

Moran Furniture has a team of dedicated staff, expertly trained in their fields, some whom have been with the company for over twenty years.

The collective passion and commitment continues today, staying true to John's vision, which keeps the company going from strength to strength.

Our history is important to us. It reminds us of the hard work, dedication and pride we have in the product we offer to Australians. We pass this on to you through delivering good old fashioned service and dedication in positively contributing to Australian design, and keeping handcrafting techniques of manufacturing alive.

So when you purchase a Moran product you can be confident in our slogan.

Relax, it's Moran, Relax in Style.



OUR CONSTRUCTION

An investment in handmade luxury.

Moran's underlying quality begins with a structurally correct frame, strength and integrity. Its high load-bearing capacity ensures lasting support and durability that is not always evident in lighter weight furniture.

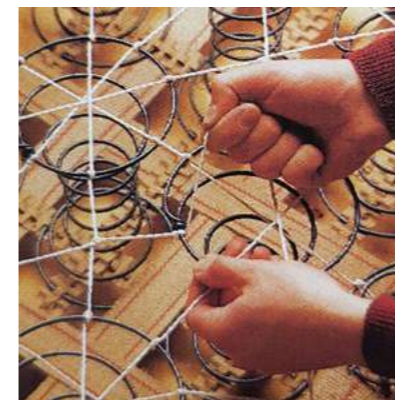

8-WAY HAND TIED SPRUNG SEAT BASE & EDGE

Traditional construction methods using eight-way hand-tied cushion support; this is accepted that the finest and most comfortable seat has an eight-way hand-tied hourglass spring system, providing independent support for each person. Available on selected models.

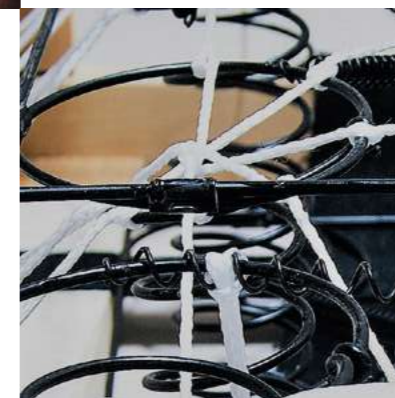

CONTEMPORARY SPRUNG SEAT BASE

Contemporary non-sag springs; for those models that require a more slimline construction for cushion support seat and back with built-in lumbar support. This innovation in tension and suspension control provides resiliency and performance that extends furniture life. Standard as applicable to each model.



INTEGRATED LUMBAR SUPPORT

Integrated lumbar support; tempered steel springs and sculptured padded backrests are individually adapted to each model to provide healthy lower back support eliminating seated spine pressure. Standard as applicable to each model.



This ultimate in seating construction was previously only available in the world's most prestigious furniture; Moran puts it within everyone's reach.

Moran believes that good furniture should be built by hand from the inside out, resulting in truly beautiful upholstered furniture that provides the ultimate in supportive comfort and exquisite level of refined tailoring that will stand the test of time.



MORAN BRITNEY - SUITE
DISPLAYED IN: MORAN FABRIC & CHROME LEGS
SHOWING: 3.0 SEAT SOFA, CHAIR & OTTOMAN

Everyone deserves well-made furniture that is good for your body.

Make your house a home, one that invites you to relax and enjoy your life in the best possible way every day. There is no place more important than home and our guiding belief that 'everyone deserves well-made furniture that is good for your body' is why 'comfort' is what Moran is all about.

Moran comfort gives the level of relaxation that is essential to good health and well-being and underpins every design that we make without compromising on style.

For your body to be truly comfortable your sofa or chair has to be more than soft. A lot goes into making a seat that offers support in such a manner that the initial comfort continues to provide long-lasting comfort.

Moran furniture is purposely designed to position your entire body in as weightless a state as possible – gently distributing weight to alleviate pressure points so your muscles can truly relax from head-to-toe, rather than your body seeking compromises, by repositioning itself to find relief.

Comfort is often invisible. This is especially so with upholstered furniture. The anatomy of Moran Furniture reveals the finer points of the materials and construction that combine to give you the lifelong comfort that is synonymous with the Moran brand.

When you are sitting in well-constructed furniture, your body will thank you. In fact the longer you sit, the more relaxed and rejuvenated you become.



MORAN MIRA BED
DISPLAYED IN: MORAN FABRIC & TIMBER LEGS
DAVID JONES EXCLUSIVE

Our Seat Inserts



SPRINGCELL PLUS FEATHER WRAP

A SpringCell Plus Feather Wrap insert offers the stability and support of a SpringCell seat insert combined with the added luxury of a feather quilt layer that you can sink into.

A Feather Wrap may be double or single sided as applicable to the seat depth and look applicable for the individual model. In both cases a Feather wrap will ultimately change the look of the cushion to a softer, looser appearance.

This style is for those who prefer softer cushioning and who embrace a more unstructured style on the surface, but still appreciate the body correct support of the underlying SpringCell core.

As is the nature of a feather wrap, weight on the seat will leave a surface impression that gives it its distinctive slouchy, relaxed style.

A little periodic plumping of the feather layer by dropping the cushions face down from waist height to the ground will go a long way to help keep these cushions looking their best.

The quality Japara cotton quilt covers housing the feathers are zippered in place around the core offering better distribution and ease of rejuvenation and replacement for the life of your sofa.



SPRINGCELL SEAT

A SpringCell seat insert is constructed with tempered steel springs encased in a sandwich of Dunlop Enduro foam.

Individually wrapped 2mm compressed spring coils are hand-packed within the load bearing area of the seat. The surrounding foam is then glued together to create a stable internal chamber for the coils to respond to the pressure placed upon them.

A FibreSoft wrap around this core further enhances a more evenly rounded and aesthetically pleasing cushion shape, whilst also preventing loose or worn areas from forming from within.

The standard SpringCell design has been Moran's Signature in seating support and comfort for the past 30 years as it continues to provide superior comfort and support unlike any other cushion core.

Customers who are predisposed to any back complaints are directed to this most supportive seat option.



FEATHER & FIBRE

A Feather & Fibre insert is constructed with a mix of 50% feathers and 50% man-made fibre.

Feathers are known to be the softest and most luxurious filling available. This feather & fibre mix provides a distinctive light lofty appearance, providing the ultimate casual yet sumptuous lived-in look. This look appeals to those who like to sink into their cushions.

As feathers are a natural product the light and unstructured look requires regular plumping by dropping the cushions face down from waist height to the ground to redistribute the feathers.

A little daily care will allow air to flow between the fibre mix to free the feathers from crushing to maintain its inviting comfy plump look for the greatest length of time. Naturally however, through normal use, compression will still occur during the life of your sofa.



FOAM CORE PLUS FEATHER WRAP

A Foam Core Plus Feather Wrap option consists of a high resilience Dunlop foam core surrounded by the softness of a feather wrap which fosters the relaxed lived-in appearance.

Providing a medium level of support this core provides short-term comfort and resilience than its SpringCell counterpart. Aesthetically, however, it does present a flatter rectangular shaped cushion due to the foam component and softened by the feather wrap offers a pleasing visual result.

As is the nature of a feather wrap, weight on the seat will leave a surface impression that gives it its distinctive slouchy, relaxed style.

A little periodic plumping of the feather layer by dropping the cushions face down from waist height to the ground will go a long way to help keep these cushions looking their best.

Our Back Inserts



FIBRESOFT FILL

A 100% FibreSoft Fill back is a manufactured foam filling often used for its cloud like cushion feel, that is most appealing in back cushions when couple with a supportive frame construction.

As with all man made products it is extremely durable. This option will provide many years of back support and by far is the most resilient of all back insert options.



FEATHER FILL

Feather Filled Scatter Backs are constructed with 100% feathers. Feathers are known to be the softest and most luxurious filling of all inserts, they provide a relaxed, comfortable, lived-in appearance and definitely appeal to those customers who like to sink into their cushions.

As a consequence of the feathers being a natural product, the feathers do not maintain an exact symmetrical shape and regular plumping of the insert is required to redistribute the feathers evenly and to inhibit the feathers clumping.

It is recommended that the feather/fibre insert is plumped up daily to maintain its inviting comfy lived-in look.



SPRINGCELL BACK

A Springcell back is constructed as a sandwich of Dunlop foam encapsulating 2mm springs within the load bearing area of the seat. The surrounding foam is glued together with the springs covertly placed in individual calico bags within the centre of the construction. This feature is by far the most supportive of all seat inserts, it is further enhanced with a fibresoft wrap around the foam.

Customers who are predisposed to any back complaints are directed to this most supportive seat option. The standard springcell has been the Moran signature in seating support and comfort for over the past 30 years.



All our inserts are designed with replenishment and replacement in mind, extending the natural life of your loved Moran sofa for many more years of enjoyment.

YOUR OPTIONS

Redefine Your Chosen Style of Furniture and Configuration with these Tailor-made finishing options.



MORAN FABRICS

Fabric can create an inviting and tactile experience within the home. With the breadth of colour options and textures available, as well as glorious prints to consider, the world is your oyster when it comes to creating the most memorable looks imaginable in interiors with fabric on upholstered furniture.

Our Moran Fabric selection is a refined collection; representing a considered and consolidated range of highly desirable looks and colours from trusted mills and leading fabric houses, ensuring quality finishing, fashionability, exceptional value and lasting enjoyment.

TIMBER COLORS

Co-ordinated timber colour throughout a home can create the ultimate high-end look. Our timber colour range offers a comprehensive selection of fashionable, neutral based colours to tie back seamlessly with other popular classic and contemporary timber furniture and finishes, to make achieving a coordinated look you desire, a breeze.



French White Grey Donkey Light Antique Walnut Antique Walnut Chocolate



Black Ash Oak

MORAN LEATHERS

Simply nothing quite compares to the sensual feel and graceful ageing of full-grain leather upholstery. Moran only sources quality hides from the world's best tanneries. From classic to contemporary the Moran Leather range offers a sophisticated palette of leather looks and colours so that you can tailor your selection to your budget, aesthetic and lifestyle for simply breath-taking results.

MORAN ANTIQUE

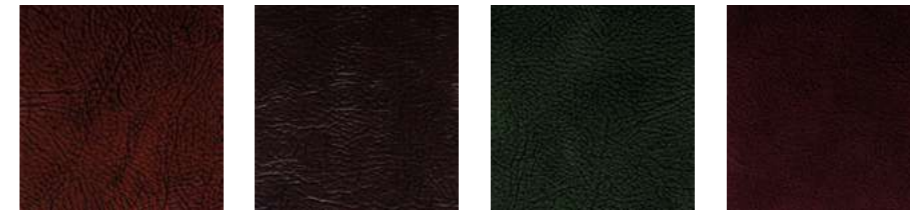

Burgundy Muscatel Olive Shiraz

MORAN PREMIUM



Almond Dove Garnet Indigo Ivy Malt



Merangue Mollasses Onyx Porcini Smoke Teal

MORAN STERLING



Cafe Noir Cardinal Cocoa Latte Vanilla White

MORAN VINTAGE

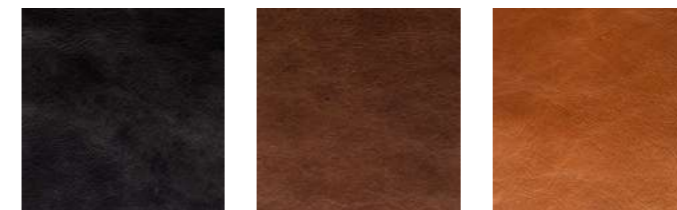

Graphite Mahogany Whiskey



MORAN MAISON - SUITE
DISPLAYED IN: MORAN FABRIC & GLIDES
SHOWING: 3.0 SEAT SOFA, CHAIR & OTTOMAN
DAVID JONES EXCLUSIVE

OUR FINISHING TOUCHES

Luxury for everyday living.

Details are everything!

When an appreciation for loving skills and attention to detail counts, look no further than Moran Furniture. Forever striving to deliver the best quality without neglecting a distinctive style, Moran Furniture finds the ultimate balance for each design.



Hand Buttoning



Hand Studding



Unique Feature For Each Model



Arm Caps Supplied With Fabric Models



Hand Rubbed Leather Finishes



Zipped-In Seat And Back Cushions For Easy Cleaning



Loose Covers Available On Selected Models



Quality Fittings

2 0 1 9 / 2 0

Furniture Catalogue

This beautiful collection of fine, Australian designed furniture, is amongst the most comfortable you will find anywhere in the world.

We hope you enjoy the breadth of styles and configuration options we offer as we endeavour to help you create your dream home.

Home is and always will be the nucleus of our individual universe; where we should feel the most at ease. Certainly a home is the most endearing when it reflects our personal tastes and way of life. So whatever style attracts you in this book, be excited by the possibilities. Express your personal style and be secure in the knowledge that we will ensure that your investment is easy on the eye and especially so on your body.

In our 60 plus year history, our range has and will continue to evolve, as a reflection of the tastes and trends important to Australians, while the quality and service support we offer is consistently second to none.

We invite you to share in the experience of why so many Australians choose Moran Furniture. At the end of the day you deserve to just sit back and relax.

Relax in Style, Moran

All designs contained herein are owned/registered and remain the Intellectual property of Moran Furniture Pty Ltd. The furniture models and manufacture described in this literature relate exclusively to the designs produced by Moran Furniture. Availability of cover shown is subject to change. Improvements or alterations to design, construction techniques or dimensions may occur without notice.

* Our obligations are subject to our formal, written conditional guarantee.

GUARANTEED
• 10 YEARS •
IN WRITING

MORAN ROMSEY
DISPLAYED IN: MORAN FABRIC & TIMBER LEGS
SHOWING: CHAIR & FOOT STOOL



Society Accent Chair

Frame: Kiln Dried Hardwood & Structural Composites
 Seat: Contemporary Non-Sag Steel Sprung Base
 Seat Cush: SpringCell® Plus Feather Wrap
 Back: Contemporary Non-Sag Steel Sprung Back
 Back Cush: 100% Fully Upholstered Foam & Fibresoft Fill with Feather Filled 60x40cm Loose
 Cover: Fabric only
 Legs: Timber
 Detailing: Top-Stitching
 Options: Wide Selection of Moran Fabrics
 Choice of Timber Colours

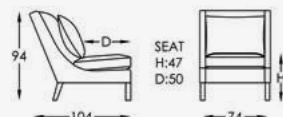

DAVID JONES EXCLUSIVE

Carter Accent Chair

Frame: Kiln Dried Hardwood & Structural Composites
 Seat: Contemporary Non-Sag Steel Sprung Base
 Seat Cush: SpringCell® Plus FibreSoft Wrap
 Back: Contemporary Non-Sag Steel Sprung Back with Integrated Lumbar Support
 Back Cush: Fully Upholstered Foam & FibreSoft Fill Fixed Back
 Cover: Fabric or Leather
 Legs: Timber
 Detailing: Self Piped Cushion Edges
 Hand Studding
 Other: Removable Seat Cushion
 Standard 'Series B' Arm Caps when in Fabric
 Options: Wide Selection of Moran Leathers & Fabrics
 Choice of Timber Colours
 Without Studding

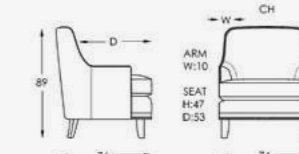

Daniela Accent Chair

Frame: Kiln Dried Hardwood & Structural Composites
 Seat: Modern Webbed Base
 Seat Cush: Fully Upholstered Foam & FibreSoft Wrap
 Back: Modern Webbed Back
 Back Cush: Fully Upholstered Foam & FibreSoft Wrap
 Cover: Leather or Fabric
 Legs: Timber
 Detailing: Tailored Stitching Detail
 Luxurious Padding
 Other: Matching Lumbar Cushion Included as Standard
 Options: Wide Selection of Moran Leathers & Fabrics
 Choice of Timber Colours

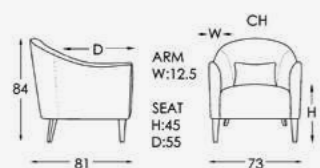

DAVID JONES EXCLUSIVE

Aero Accent Chair

Frame: Kiln Dried Hardwood & Structural Composites
 Seat: Contemporary Non-Sag Steel Sprung Base
 Seat Cush: SpringCell® Plus FibreSoft Wrap Loose Cushion
 Back: Contemporary Non-Sag Steel Sprung Back
 Back Cush: Fully Upholstered Foam & FibreSoft Wrap Fixed Back
 Cover: Leather or Fabric
 Legs: Timber
 Detailing: Self-Piped Cushion Edges
 Others: Standard 'Series B' Arm Caps when in Fabric
 Options: Wide Selection of Moran Leathers & Fabrics
 Choice of Timber Colours

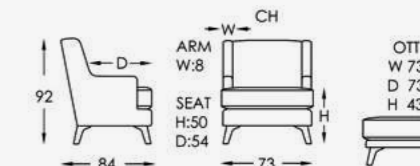

Jimmy Accent Chair

Frame: Kiln Dried Hardwood & Structural Composites
 Seat: Modern Webbed Base
 Seat Cush: SpringCell® Plus FibreSoft Wrap
 Back: Modern Webbed Back
 Back Cush: Fully Upholstered Foam & FibreSoft Fixed
 Cover: Leather or Fabric
 Legs: Timber
 Detailing: Self Piped Seat Cushion
 Other: Standard 'Series B' Arm Caps when in Fabric
 Options: Wide Selection of Moran Leathers & Fabrics
 Choice of Timber Colours

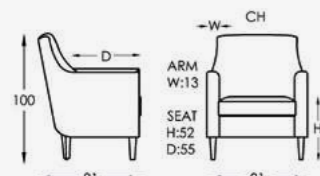

DAVID JONES EXCLUSIVE

Monet Accent Chair

Frame: Kiln Dried Hardwood & Structural Composites
 Seat: Contemporary Non-Sag Steel Sprung Base
 Seat Cush: SpringCell® Plus FibreSoft Wrap Loose Cushion
 Back: Contemporary Non-Sag Steel Sprung Back
 Back Cush: 100% FibreSoft Fill Loose Cushion
 Cover: Leather or Fabric
 Legs: Timber
 Detailing: Self-Piped Edges
 Others: Removable Seat & Back Cushions
 Standard Series B Arm Caps when in Fabric
 Options: Wide Selection of Moran Leathers & Fabrics
 Choice of Timber Colours

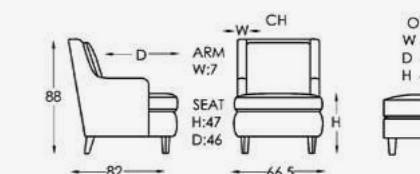

Alberta Accent Chair

Frame: Kiln Dried Hardwood & Structural Composites
 Seat: Modern Webbed Base
 Seat Cush: SpringCell® Plus FibreSoft Wrap Loose Cushion
 Back: Modern Webbed Back with Integrated Lumbar Support
 Back Cush: Fully Upholstered Foam & FibreSoft Fill Back
 Cover: Fabric Only
 Legs: Timber
 Detailing: Self-Piping
 Options: Wide Selection of Moran Fabrics
 Choice of Timber Colours

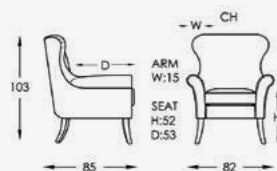

DAVID JONES EXCLUSIVE

Bugatti Accent Chair

Frame: Kiln Dried Hardwood & Structural Composites
 Seat: Contemporary Non-Sag Steel Sprung Base
 Seat Cush: SpringCell® Plus FibreSoft Wrap Loose Cushion
 Back: Contemporary Non-Sag Steel Sprung Back with Integrated Lumbar Support
 Back Cush: Fully Upholstered Foam & FibreSoft Wrap
 Cover: Leather or Fabric
 Legs: Timber with Castors
 Detailing: Ribbed/Panel Stitching on Back & Seat Top Stitching
 Other: Standard 'Series B' Arm Caps when in Fabric
 Options: Wide Selection of Moran Leathers & Fabrics
 Choice of Timber Colours
 Straight Timber Leg without Castor option
 Plain Fabrics Only

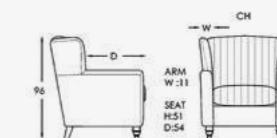

Salon Accent Chair

Frame: Kiln Dried Hardwood & Structural Composites
 Seat: Contemporary Non-Sag Steel Sprung Base
 Seat Cush: Fully Upholstered Foam & FibreSoft Wrap Fixed Cushion
 Back: Kiln Dried Hardwood & Structural Composites with Rattan Mesh Panel
 Cover: Leather or Fabric
 Legs: Timber with Plinth
 Detailing: Feature Timber Frame Curved Back Panel with Oval Timber Detail Self-Piping on Seat Cushion
 Options: Wide Selection of Moran Leathers & Fabrics
 Matching Lumbar Cushion
 Choice of Timber Colours

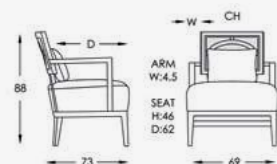

DAVID JONES EXCLUSIVE

DAVID JONES EXCLUSIVE

Celeste Accent Chair

Frame: Kiln Dried Hardwood & Structural Composites
 Seat: Contemporary Non-Sag Steel Sprung Base
 Seat Cush: SpringCell® Plus FibreSoft Wrap Fixed Cushion
 Back: Modern Webbed Back
 Back Cush: Fully Upholstered Foam & FibreSoft Wrap Fixed Back
 Cover: Leather or Fabric
 Legs: Timber
 Detailing: Self-Piped Cushion Edges Arm Pleating Hand Tied Diamond Buttoning
 Other: Standard 'Series B' Arm Caps when in Fabric
 Options: Wide Selection of Moran Leathers & Fabrics
 Choice of Timber Colours

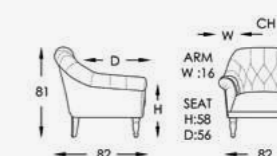

Alicia Accent Chair

Frame: Kiln Dried Hardwood & Structural Composites
 Seat: Modern Webbed Base
 Seat Cush: SpringCell® Plus FibreSoft Wrap Loose Cushion
 Back: Modern Webbed Back
 Back Cush: Fully Upholstered Foam & FibreSoft Wrap with Diamond Cut & Pulled Upholstery
 Cover: Fabric Only
 Legs: Timber
 Other: Standard 'Series B' Arm Caps
 Options: Wide Selection of Moran Fabrics
 Choice of Timber Colours

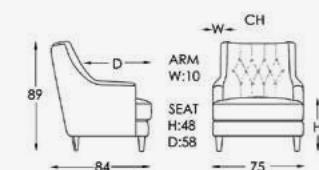

DAVID JONES EXCLUSIVE

Shelford Tub Accent Chair

Frame: Kiln Dried Hardwood & Structural Composites
 Seat: Contemporary Non-Sag Steel Sprung Base
 Seat Cush: Fully Upholstered Foam & FibreSoft Wrap Fixed Cushion
 Back: Modern Webbed Back
 Back Cush: Fully Upholstered Foam & FibreSoft Wrap
 Cover: Leather or Fabric
 Legs: Timber Legs with Castors
 Detailing: Hand Studded Arm Faces Hand-Tied Diamond Buttoning on Inside Back, Arms and Front Plinth
 Options: Wide Selection of Moran Leathers & Fabrics
 Tapered Timber Legs to Replace Timber Legs with Castors
 Choice of Timber Colours
 Piping to Replace Studs

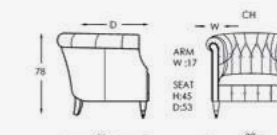

Juno Accent Chair

Frame: Kiln Dried Hardwood & Structural Composites
 Seat: Contemporary Non-Sag Steel Sprung Base
 Seat Cush: Foam SpringCell® Plus Feather Wrap
 Back: Modern Webbed Back with Integrated Lumbar Support
 Back Cush: Down & Feather Fill Back Cushions
 Cover: Leather or Fabric
 Legs: Timber
 Detailing: Self-Piping
 Hand Studding
 Options: Wide Selection of Moran Leathers & Fabrics
 Choice of Timber Colours
 Piping to Replace Hand Studding

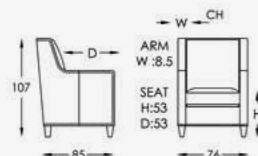

Professor Accent Chair

Frame: Kiln Dried Hardwood & Structural Composites
 Seat: Contemporary Non-Sag Steel Sprung Base
 Seat Cush: SpringCell® Plus Feather Wrap
 Back: Fully Upholstered Webbed Back
 Cover: Leather or Fabric
 Legs: Timber
 Detailing: Self-Piping on Seat Cushion
 Hand Studding
 Options: Wide Selection of Moran Leathers & Fabrics
 Choice of Timber Colours
 Piping to Replace Hand Studding

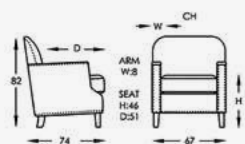

Boston Accent Chair

Frame: Kiln Dried Hardwood & Structural Composites
 Seat: Contemporary Non-Sag Steel Sprung Base
 Seat Cush: SpringCell® Plus FibreSoft Wrap
 Back: Contemporary Non-Sag Steel Sprung Back with Integrated Lumbar Support
 Back Cush: Fully Upholstered Foam & FibreSoft Wrap Fixed
 Cover: Leather or Fabric
 Legs: Turned Timber
 Detailing: Self Piping
 Options: Wide Selection of Moran Leathers & Fabrics
 Choice of Timber Colours

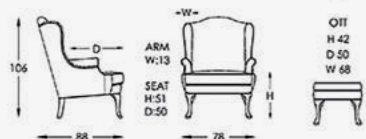

DAVID JONES EXCLUSIVE

Romsey Accent Chair

Frame: Kiln Dried Hardwood & Structural Composites
 Seat: Contemporary Non-Sag Steel Sprung Base
 Seat Cush: SpringCell® Plus FibreSoft Wrap
 Back: Contemporary Non-Sag Steel Sprung Back with Integrated Lumbar Support
 Back Cush: Fully Upholstered Diamond Buttoned Foam & FibreSoft Wrap
 Cover: Leather or Fabric
 Legs: Turned Timber
 Detailing: Self-Piping
 Hand Studding
 Options: Wide Selection of Moran Leathers & Fabrics
 Choice of Timber Colours
 Piping to Replace Studding

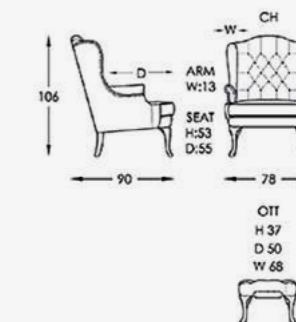

DAVID JONES EXCLUSIVE

Abbey Recliner Chair

Frame: Kiln Dried Hardwood & Structural Composites
 Seat: Contemporary Non-Sag Steel Sprung Base
 Seat Cush: SpringCell® Plus FibreSoft Wrap Fixed
 Back: Contemporary Non-Sag Steel Sprung Back with Integrated Lumbar Support
 Back Cush: Fully Upholstered Foam & FibreSoft Wrap
 Cover: Leather or Fabric
 Legs: Turned Timber
 Detailing: Wing Back Chair Style with Concealed Smooth Action Foot Rest Recline
 Self-Piped Edges
 Other: Recliner Chair: Motorised Recline Action with Cordless Control (Rechargeable Battery)
 120kg User Limit Recommended
 Standard Series 'B' Arm Caps when in Fabric
 Options: Wide Selection of Moran Leathers & Fabrics
 Choice of Timber Colours

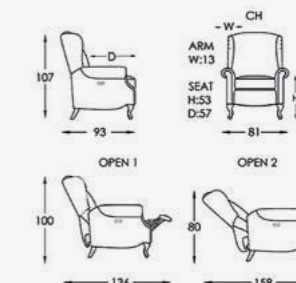

WHY CHOOSE MORAN RECLINERS?

At Moran, we utilise the highest-grade foams, padding, and fillers to allow for each model to achieve optimal aesthetics and structured good looks, bringing lasting luxury and visual enjoyment, for pieces that look as good as they feel.



01
RIGHT NECK &
HEAD SUPPORT

02
LOWER
BACK SUPPORT

03
CORRECT SEAT DEPTH
FOR COMFORT

04
PERFECT ARM POSITION

05
RIGHT SEAT WIDTH &
HEIGHT FOR COMFORT

06
WALLSAVER FEATURE
(Except in Push-Back)



DAVID JONES EXCLUSIVE



Olympus Recliner Chair

Back: Contemporary Webbed Back
Back Cush: 100% FibreSoft Fill
Action: Legget & Platt Recliner Mechanism
Detailing: Wrap-Over Chaise
Tailored Twin-Needle Stitching
Contemporary Square Arm Design
Other: 120kg User Limit Recommended
Options: Recliner Chairs & Sofas as Manual, Sensor Control, Motorised, Motorised Lift Option, Recliner Control Options – Manual Handle/Trigger, Motorised Dual Button or Touch Sensors (RH or LH Inside Arm Option for Sensor Only)

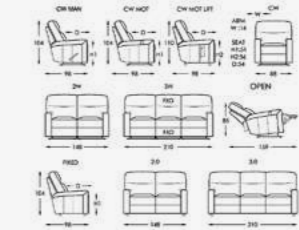

Cloud Recliner Chair

Back: Contemporary Non-Sag Steel Sprung Back with Integrated Lumbar Support
Back Cush: FibreSoft Fill & Foam Core Waterfall Style
Detailing: Twin Needle Stitching
Wrap-Over Chaise
Padded Arm Rests
Upholstered RH Handle on Chair as Standard
Other: Finger Tip Release on 2.0S & 3.0S as Standard
Standard Series B Arm Caps when in Fabric
Options: 120kg User Limit Recommended
Recliner Chairs as Manual, Motorised or Motorised with Lift
Recliner Sofas as Manual, Motorised, Fixed LH Upholstered Handle or FingerTip Release

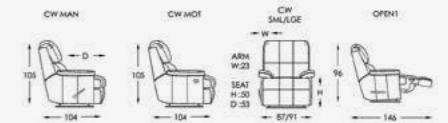

All our Recliners Feature:

Frame: Kiln Dried Hardwood & Structural Composites
Seat: Contemporary Non-Sag Steel Sprung Base
Seat Cush: SpringCell® Plus FibreSoft Wrap
Cover: Leather or Fabric
Options: Available in a Wide Selection of Moran Leathers & Fabrics

Sultan Recliner Chair

Back: Modern Webbed
Back Cush: 100% FibreSoft Fill Fixed Cushions
Action: Legget & Platt Recliner Mechanism
Other: 120kg User Limit Recommended
RH Fingerlip Release as Standard
Options: Upholstered Handle to Replace FingerTip Release
LH Upholstered Handle or Finger Tip Release
Recliner Chairs as Manual, Motorised or Motorised with Lift
Sofas as Manual, Motorised or Fixed

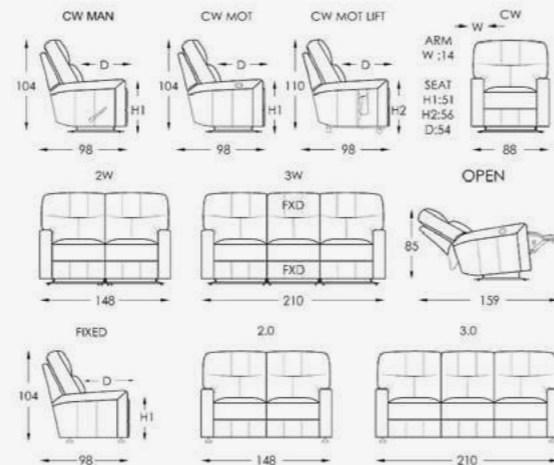

Pilot Recliner Chair

Back: Modern Webbed Back
Back Cush: 100% FibreSoft Fill
Detailing: Top-Stitching
Other: 120kg User Limit Recommended
RH Fingerlip Release as Standard
Options: Upholstered Handle to Replace FingerTip Release
Recliner Chairs as Manual, Motorised or Motorised with Lift
Sofas as Manual, Motorised or Fixed

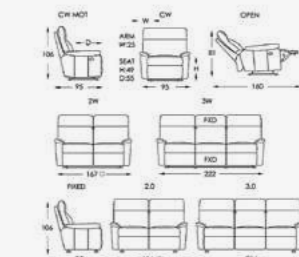

Spoillette Recliner Chair

Back: Modern Webbed Back
 Back Cush: 100% FibreSoft Fill Zipped Cushion
 Detailing: Wallsaver Recliner
 Upholstered RH Handle
 Neat Pop-Up Mid-Ottoman
 Arm Caps when in Fabric
 Other: 120kg User Limit Recommended
 Options: Firmer SpringCell® Seat Cushion
 LH Handle
 RH or LH Finger Tip Release
 Fabric Protection

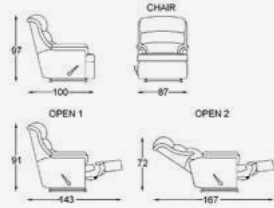

Admiral Recliner Chair

Back: Contemporary Non-Sag Steel Sprung Back
 Back Cush: 100% FibreSoft Fill Fixed Cushions
 Detailing: Wrap-Over Chaise
 Padded Arm Rests
 Tailored Stitching Lines
 Slim Modern Design
 Other: 120kg User Limit Recommended
 RH Fingerlip Release as Standard
 Options: Upholstered Handle to Replace FingerTip Release
 LH Upholstered Handle or Finger Tip Release
 Recliner Chairs as Manual, Motorised or Motorised with Lift
 Sofas as Manual, Motorised or Fixed

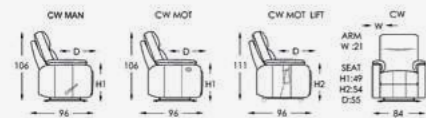

Triple Crown W/Chaise Recliner Chair

Back: Contemporary Non-Sag Steel Sprung Back
 Back Cush: Fully Upholstered FibreSoft Fill & Foam Core
 Waterfall Styled
 Detailing: Wallsaver Recliner
 Upholstered RH Handle
 Wrap Over Chaise
 Finger Tip Release on 2.0S Recliner
 Fixed Settee Seat Cushions Zipped
 Arm Caps when in Fabric
 Other: 120kg User Limit Recommended
 Options: Firmer SpringCell® Seat Cushion
 Motorised, Motorised with Lift
 LH Upholstered Handle on Chair
 LH or RH Finger Tip Release on Chair
 Fabric Protection

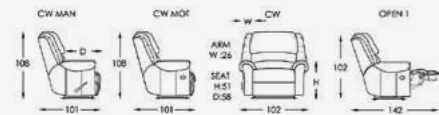

Experience the Ultimate Comfort.

Ergonomically designed – Moran Active Comfort chairs are notably compact, stylish and incredibly versatile, and developed with the pursuit of ultimate personal relaxation in mind.



MORAN ACTIVE COMFORT RANGE



Grand
Active Comfort
DAVID JONES EXCLUSIVE



Jetty
Active Comfort
DAVID JONES EXCLUSIVE



Magnet
Active Comfort



Fusion
Active Comfort



Voyager
Active Comfort



Maitland
Active Comfort



Langham
Active Comfort



Raleigh
Active Comfort



Mia
Active Comfort



Cozy
Active Comfort



Olsen Sofa Chair

Frame: Kiln Dried Hardwood & Structural Composites
 Seat: Contemporary Non-Sag Steel Sprung Base
 Seat Cush: SpringCell® Plus FibreSoft Wrap
 Back: Contemporary Non-Sag Steel Sprung Back
 Back Cush: 100% FibreSoft Fill
 Cover: Leather or Fabric
 Legs: Black Metal
 Detailing: Top Stitched Edges
 Other: Standard 'Series B' Arm Caps when in Fabric
 Options: Wide Selection of Moran Leathers & Fabrics

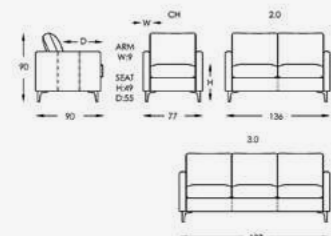

DAVID JONES EXCLUSIVE



York Sofa Chair

Frame: Kiln Dried Hardwood & Structural Composites
 Seat: Contemporary Non-Sag Steel Sprung Base
 Seat Cush: SpringCell® Plus FibreSoft Wrap Zipped-In
 Back: Modern Webbed Back
 Back Cush: 100% FibreSoft Fill Back Zipped-In Cushions
 Cover: Leather or Fabric
 Legs: Timber
 Detailing: Top-Stitching
 Other: Seat & Back Cushions Harnessed
 Options: Wide Selection of Moran Leathers & Fabrics
 Choice of Timber Colours on Legs

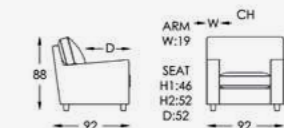

Elwood Sofa Chair

Frame: Kiln Dried Hardwood & Structural Composites
 Seat: Contemporary Non-Sag Steel Sprung Base
 Seat Cush: SpringCell® Plus FibreSoft Wrap
 Back: Contemporary Non-Sag Steel Sprung Back
 Back Cush: SpringCell® Plus FibreSoft Wrap
 Cover: Leather or Fabric
 Legs: Chrome
 Detailing: Self-Piping
 Blind Buttoning Upholstery
 Standard 'Series B' Arm Caps when in Fabric
 Other: Seat & Back Cushions Zipped-In
 Options: Wide Selection of Moran Leathers & Fabrics
 Choice of Timber Colours
 Twin Stitch Detail to Replace Self Piping

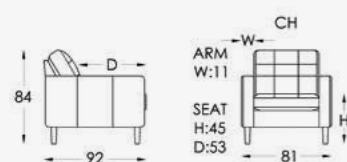

Oliver Sofa Chair

Frame: Kiln Dried Hardwood & Structural Composites
 Seat: 8 Way Hand Tied Steel Sprung Base
 Seat Cush: SpringCell® Plus FibreSoft Wrap
 Back: Contemporary Non-Sag Steel Sprung Back with Integrated Lumbar Support
 Back Cush: 100% FibreSoft Fill
 Cover: Leather or Fabric
 Legs: Timber
 Detailing: Top-Stitching with Piping
 Seat & Back Cushions Zipped-In
 Other: Standard 'Series B' Arm Caps when in Fabric
 Options: Wide Selection of Moran Leathers & Fabrics
 SpringCell® Plus FeatherWrap Seat Cushion
 Choice of Timber Colours

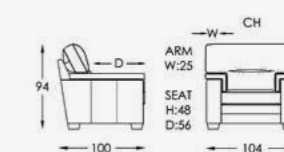

Sienna Sofa Chair

Frame: Kiln Dried Hardwood & Structural Composites
 Seat: Contemporary Non-Sag Steel Sprung Base
 Seat Cush: SpringCell® Plus Feather Wrap
 Back: Contemporary Non-Sag Steel Sprung Back
 Back Cush: 100% FibreSoft Fill Loose Back Cushions
 Cover: Leather or Fabric
 Legs: Timber
 Detailing: Buttoning Detail on Back Cushions
 Self Piped
 Other: Seat & Back Cushions Harnessed for Easy Removal & Cleaning
 Options: Wide Selection of Moran Leathers & Fabrics
 Choice of Timber Colours

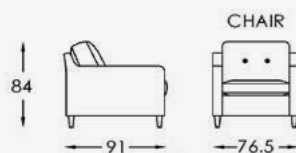

DAVID JONES EXCLUSIVE

Maison Sofa Chair

Frame: Kiln Dried Hardwood & Structural Composites
 Seat: Contemporary Non-Sag Steel Sprung Base
 Seat Cush: SpringCell® Plus Feather Wrap Loose Cushions
 Back: Modern Webbed Back
 Back Cush: Feather and FibreSoft Fill Loose Cushions
 Cover: Fabric Only/ Loose Cover Only
 Legs: Glides
 Detailing: Self-Piping
 Other: Standard 'Series B' Arm Caps
 Options: Wide Selection of Moran Fabrics

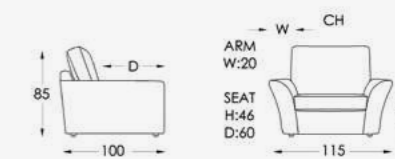

Claire Sofa Chair

- Frame: Kiln Dried Hardwood & Structural Composites
- Seat: Contemporary Non-Sag Steel Sprung Base
- Seat Cush: SpringCell® plus Feather Wrap
- Back: Contemporary Non-Sag Steel Sprung Back with Integrated Lumbar Support
- Back Cush: 100% FibreSoft Fill
- Cover: Leather or Fabric
- Legs: Timber with Brass Castor
- Detailing: Self Piping on Cushions
Arm Pleating
- Other: Standard 'Series B' Arm Caps when in Fabric
- Options: Straight Timber Leg without Castor
Wide Selection of Moran Leathers & Fabrics
Choice of Timber Colours
Foam plus Feather Wrap Seat Cushion

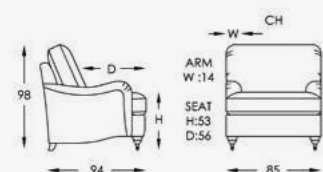

DAVID JONES EXCLUSIVE



DAVID JONES EXCLUSIVE

Marlin Sofa Chair

- Frame: Kiln Dried Hardwood & Structural Composites
- Seat: 8 Way Hand Tied Fully Sprung Seat Base
- Seat Cush: SpringCell® Plus Feather Wrap
- Back: Contemporary Non-Sag Steel Sprung Back with Integrated Lumbar Support
- Back Cush: Feather & Fibre Fill
- Cover: Leather or Fabric
- Legs: Timber
- Detailing: Hand Studding along Arms & Front Plinth
Self-Piping on Cushion Edges
- Other: Luxurious Layer of extra Foam Padding on Arms
Seat & Back Cushions Zipped-In
Standard 'Series B' Arm Caps when in Fabric
- Options: Wide Selection of Moran Leathers & Fabrics
Choice of Timber Colours
Piping to Replace Hand Studding

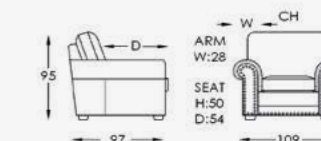
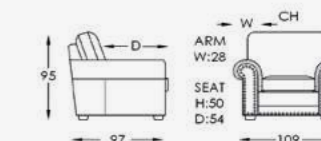

Wellington Sofa Chair

- Frame: Kiln Dried Hardwood & Structural Composites
- Seat: Contemporary Non-Sag Steel Sprung Base
- Seat Cush: SpringCell® Plus FibreSoft Wrap Zipped-In
- Back: Contemporary Non-Sag Steel Sprung Back
- Back Cush: Diamond Buttoned Fully Upholstered Foam & FibreSoft Wrap
- Cover: Leather Only
- Legs: Glides with High Impact Surrounds
- Detailing: Self-Piping
Hand Studding
- Options: Available in a Wide Selection of Moran Leathers

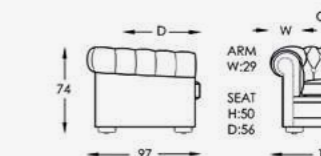
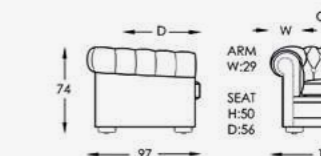

Alexis Sofa Chair

- Frame: Kiln Dried Hardwood & Structural Composites
- Seat: Modern Webbed Base
- Seat Cush: Fully Upholstered SpringCell® Plus FibreSoft Wrap
- Back: Modern Webbed Base
- Back Cush: Fully Upholstered Foam & FibreSoft Wrap
- Cover: Fabric Only
- Legs: Timber Plinth
- Detailing: Self Piping
Pleated Back
- Options: Wide Selection of Moran Fabrics
Choice of Timber Colours

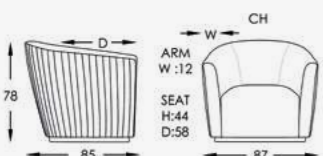

DAVID JONES EXCLUSIVE





MORAN YORK - SUITE
DISPLAYED IN: MORAN LEATHER & TIMBER LEGS
SHOWING: 3.0 SEAT SOFA & CHAIRS

Omaha 2-4 Seater Sofa

- Frame: Kiln Dried Hardwood & Structural Composite
- Seat: Contemporary Non-Sag Steel Sprung Base
- Seat Cush: SpringCell® Plus FibreSoft Wrap
- Back: Non-Sag Steel Sprung Back with Integrated Lumbar Support
- Back Cush: 100% FibreSoft Fill
- Cover: Leather or Fabric
- Legs: Timber
- Detailing: Seamless Roll-Over Cushions
Top-Stitching to Edges
Twin-Needle
Stitching to Arm & Plinth Panels
- Other: Removable Seat & Back Cushion
- Options: Wide Selection of Moran Leathers & Fabrics
Choice of Timber Colours

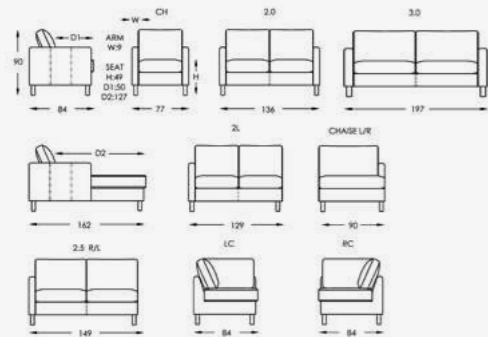

DAVID JONES EXCLUSIVE

Ontario 2-4 Seater Sofa

- Frame: Kiln Dried Hardwood & Structural Composites
- Seat: Contemporary Non-Sag Steel Sprung Base
- Seat Cush: SpringCell® Plus FibreSoft Wrap
- Back: Contemporary Non-Sag Steel Sprung Back
- Back Cush: SpringCell® Plus FibreSoft Wrap
- Cover: Leather or Fabric
- Legs: Wide Timber
- Detailing: Tailored Stitching Detail
- Options: Wide Selection of Moran Leathers & Fabrics
Choice of Timber Colours
Twin-Needle Stitch Finishing
Top Stitch Finishing

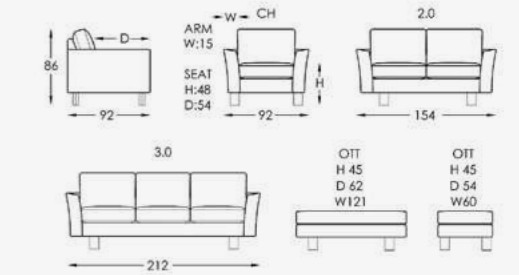

Norton 2-4 Seater Sofa

- Frame: Kiln Dried Hardwood & Structural Composites
- Seat: Contemporary Non-Sag Steel Sprung Base
- Seat Cush: SpringCell® Plus FibreSoft Wrap
- Back: Contemporary Non-Sag Steel Sprung Back with Integrated Lumbar Support
- Back Cush: SpringCell® Plus FibreSoft Wrap
- Cover: Leather or Fabric
- Legs: Chrome Steel
- Detailing: Top-Stitching
Seat and Back Cushions Zipped-In
- Other: Wide Selection of Moran Leathers & Fabrics
Timber Legs to replace Steel Legs
Choice of Timber Colours

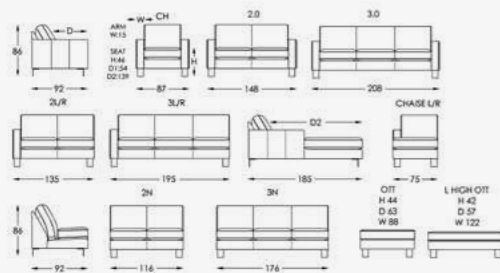

DAVID JONES EXCLUSIVE

Mika 2-4 Seater Sofa

- Frame: Kiln Dried Hardwood & Structural Composites
- Seat: Contemporary Non-Sag Steel Sprung Base
- Seat Cush: SpringCell® Plus FibreSoft Wrap
- Back: Modern Webbed Back
- Back Cush: 100% FibreSoft Fill Loose Back Cushions
FibreSoft Fill Bolster Cushions
- Cover: Leather or Fabric
- Legs: Timber
- Detailing: Self Piping
Twin Needle Stitching
Standard 'Series B' Arm Caps when in Fabric
Seat Cushions Harnessed for Easy Removal & Cleaning
- Options: Wide Selection of Moran Leathers & Fabrics
Firmer SpringCell® Seat Cushion
Choice of Timber Colours

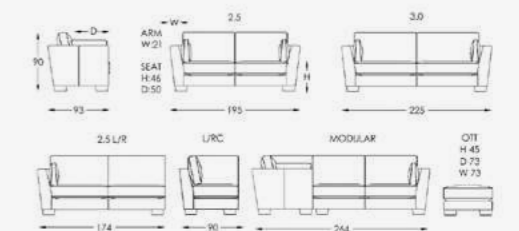

Sienna 2-4 Seater Sofa

- Frame: Kiln Dried Hardwood & Structural Composites
- Seat: Contemporary Non-Sag Steel Sprung Base
- Seat Cush: SpringCell® Plus FibreSoft Wrap
- Back: Contemporary Non-Sag Steel Sprung Back
- Back Cush: 100% FibreSoft Fill Loose Back Cushions
- Cover: Leather or Fabric
- Legs: Timber
- Detailing: Buttoning Detail on Back Cushions
Self Piped
- Other: Seat & Back Cushions Harnessed for Easy Removal & Cleaning
- Options: Wide Selection of Moran Leathers & Fabrics
Choice of Timber Colours

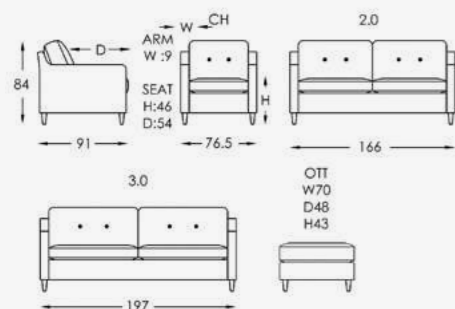

Talia 2-4 Seater Sofa

- Frame: Kiln Dried Hardwood & Structural Composites
- Seat: Contemporary Non-Sag Steel Sprung Base
- Seat Cush: SpringCell® Plus Feather Wrap Zipped-In
- Back: Contemporary Non-Sag Steel Sprung Back with Integrated Lumbar Support
- Back Cush: 100% FibreSoft Fill Zipped-In
- Cover: Leather or Fabric
- Legs: Timber
- Detailing: Top-Stitching
Luxurious Padded Arm Tops
- Other: Front Timber Plinth
- Options: Wide Selection of Moran Leathers & Fabrics
Choice of Timber Colours

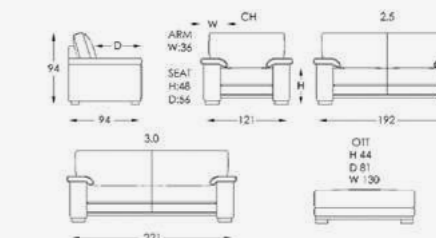

Elwood 2-4 Seater Sofa

- Frame: Kiln Dried Hardwood & Structural Composites
- Seat: Contemporary Non-Sag Steel Sprung Base
- Seat Cush: SpringCell® Plus FibreSoft Wrap
- Back: Contemporary Non-Sag Steel Sprung Back
- Back Cush: SpringCell® Plus FibreSoft Wrap
- Cover: Leather or Fabric
- Legs: Timber
- Detailing: Self-Piped
Blind Buttoning Upholstery
Standard 'Series B' Arm Caps when in Fabric
- Other: Seat & Back Cushions Zipped-In
- Options: Wide Selection of Moran Leathers & Fabrics
Choice of Timber Colours
Twin Stitch Detail to Replace Self Piping

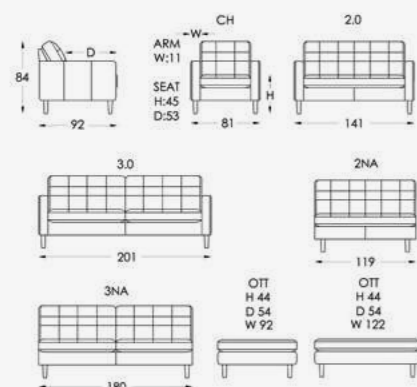

Thomas 2-4 Seater Sofa

- Frame: Kiln Dried Hardwood & Structural Composites
- Seat: Contemporary Non-Sag Steel Sprung Base
- Seat Cush: SpringCell® Plus Feather Wrap Seat Cushions
- Back: Contemporary Non-Sag Steel Sprung Back with Integrated Lumbar Support
- Back Cush: 100% FibreSoft Fill
- Cover: Leather or Fabric
- Legs: Timber
- Detailing: Top-Stitching
- Options: Wide Selection of Moran Leathers & Fabrics
Firmer SpringCell® Seat Cushions
Choice of Timber Colours

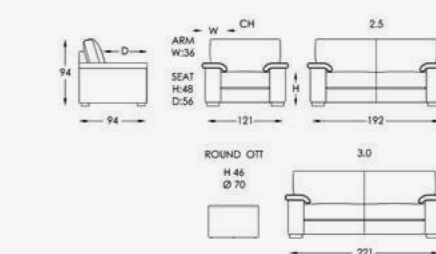

DAVID JONES EXCLUSIVE

Oslo 2-4 Seater Sofa

- Frame: Kiln Dried Hardwood & Structural Composites
- Seat: Contemporary Non-Sag Steel Sprung Base
- Seat Cush: SpringCell® Plus FibreSoft Wrap
- Back: Non-Sag Steel Sprung with Integrated Lumbar Support
- Back Cush: SpringCell® Plus FibreSoft Wrap
- Cover: Leather or Fabric
- Legs: Chrome Coated Steel
- Detailing: Top-Stitching
- Other: Seat and Back Cushions Zipped-In Standard 'Series B' Arm Caps when in Fabric
- Options: Wide Selection of Moran Leathers & Fabrics
Timber Legs to replace Chrome
Choice of Timber Colours

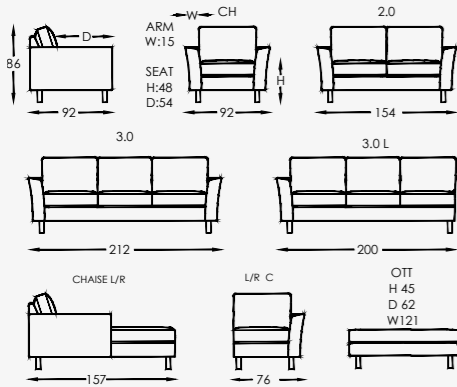

DAVID JONES EXCLUSIVE

Brubeck 2-4 Seater Sofa

- Frame: Kiln Dried Hardwood & Structural Composites
- Seat: Contemporary Non-Sag Steel Sprung Base
- Seat Cush: SpringCell® Plus FibreSoft Wrap
- Back: Contemporary Non-Sag Steel Sprung Back (Modern Webbed Back on Sofa bed)
- Back Cush: 100% FibreSoft Filled Zipped-In Cushions
- Cover: Leather or Fabric
- Legs: Timber
- Detailing: Top-Stitching
- Sleep Sys: Quilted Inner Spring Mattress
Single (W) 92cm x (L) 184cm x (D) 13cm
King Single (W) 102cm x (L) 184cm x (D) 13cm
Double (W) 132cm x (L) 184cm x (D) 13cm
Queen (W) 152cm x (L) 184cm x (D) 13cm
Counter Balanced Mechanism
- Other: Seat Cushions Harnessed on Settee, Loose on Sofa bed
- Options: Available as a Settee or Sofa Bed
Wide Selection of Moran Leathers & Fabrics
Choice of Timber Colours

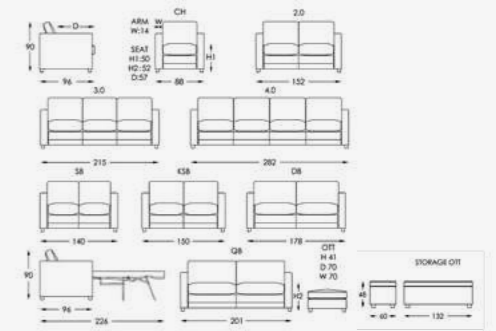

Burgess 2-4 Seater Sofa

- Frame: Kiln Dried Hardwood & Structural Composites
- Seat: Contemporary Non-Sag Steel Sprung Base
- Seat Cush: SpringCell® Plus FibreSoft Wrap
- Back: Contemporary Non-Sag Steel Sprung Back with Integrated Lumbar Support
- Back Cush: SpringCell® Plus FibreSoft Wrap
- Cover: Leather or Fabric
- Legs: Timber
- Detailing: Double Stitching
Padded Arm Tops
- Other: Standard 'Series B' Arm Caps when in Fabric
- Options: Wide Selection of Moran Leathers & Fabrics
Choice of Timber Colours

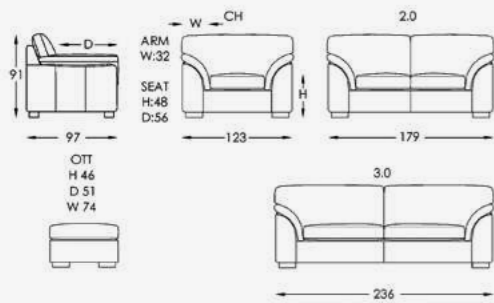

Brooklyn 2-4 Seater Sofa

- Frame: Kiln Dried Hardwood & Structural Composites
- Seat: Contemporary Non-Sag Steel Sprung Base
- Seat Cush: SpringCell® Plus FibreSoft Wrap Zipped-In
- Back: Contemporary Non-Sag Steel Sprung Back with Integrated Lumbar Support
(Sofa Bed: Modern Webbed Back)
- Back Cush: 100% FibreSoft Fill Loose Cushions
- Cover: Leather or Fabric
- Legs: Timber
- Detailing: Self Piping
- Other: Standard 'Series B' Arm Caps when in Fabric
- Sleep Sys: Quilted Inner Spring Mattress:
Double (W) 131cm x (L) 184cm x (D) 13cm
Counter Balanced Mechanism with TV Headrest on DB Mechanism
- Options: Wide Selection of Moran Leathers & Fabrics
Choice of Timber Colours

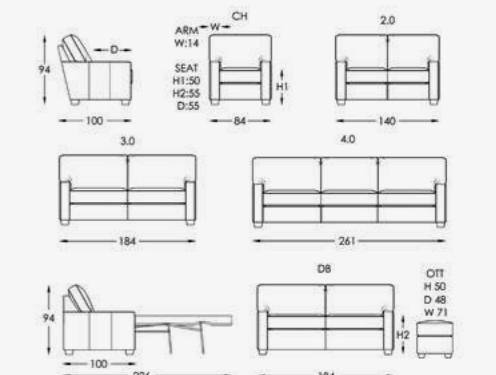



MORAN RENOIR - SUITE
DISPLAYED IN: MORAN FABRIC & TIMBER LEGS WITH PLINTH
SHOWING: 3.0 SEAT SOFA OTTOMAN & CHAIR

Carlo

2-4 Seater Sofa

Frame: Kiln Dried Hardwood & Structural Composites
 Seat: Contemporary Non-Sag Steel Sprung Base
 Seat Cush: SpringCell® Plus FibreSoft Wrap
 Back: Contemporary Non-Sag Steel Sprung Back with Integrated Lumbar Support
 Back Cush: SpringCell® Plus FibreSoft Wrap
 Cover: Leather or Fabric
 Legs: Timber
 Detailing: Self-Piping
 Other: Standard 'Series B' Arm Caps when in Fabric
 Options: Wide Selection of Moran Leathers & Fabrics
 Corner Modular Configurations
 Choice of Timber Colours
 Choice of Timber Plinth Base or Timber Legs

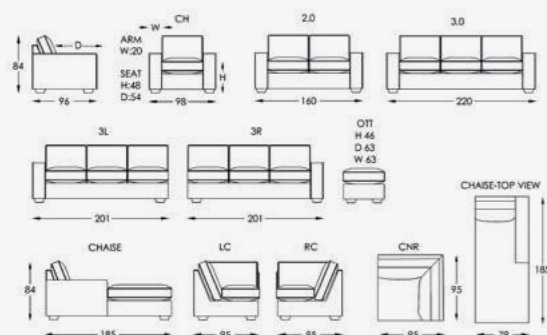

Avondale

2-4 Seater Sofa

Frame: Kiln Dried Hardwood & Structural Composites
 Seat: 8 Way Hand Tied
 Seat Cush: SpringCell® Plus FibreSoft Wrap
 Back: Modern Webbed
 Back Cush: 100% FibreSoft Wrap
 Cover: Leather or Fabric
 Legs: Chrome Steel
 Detailing: Top-Stitching
 Sleigh Like Arm with Curved Back End
 Other: Standard 'Series B' Arm Caps when in Fabric
 Options: Wide Selection of Moran Leathers & Fabrics
 SpringCell® Plus Feather Wrap Seat Cushion

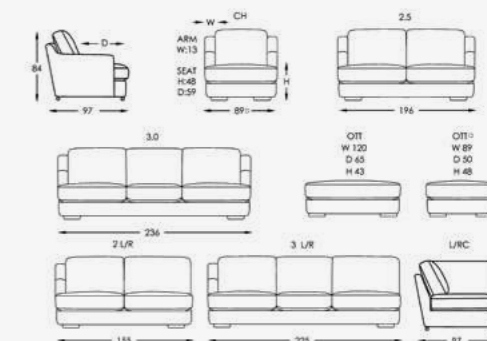

Britney

2-4 Seater Sofa

Frame: Kiln Dried Hardwood & Structural Composites
 Seat: Contemporary Non-Sag Steel Sprung Base
 Seat Cush: SpringCell® Plus FibreSoft Wrap Zipped-In
 Back: Contemporary Non-Sag Steel Sprung Back with Integrated Lumbar Support
 Back Cush: 100% FibreSoft Fill Zipped-In
 Cover: Leather or Fabric
 Legs: Chrome Coated Stainless Steel
 Detailing: Double Stitching
 Other: Standard 'Series B' Arm Caps when in Fabric
 Options: Wide Selection of Moran Leathers & Fabrics
 Timber Legs to Replace Steel Legs
 Choice of Timber Colours on Timber Legs

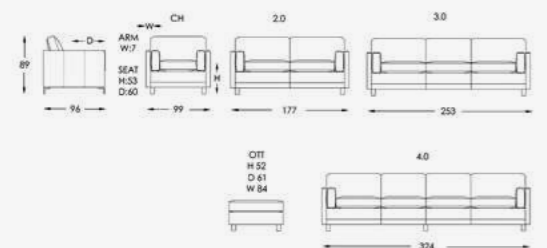

Casino

2-4 Seater Sofa

Frame: Kiln Dried Hardwood & Structural Composites
 Seat: 8 Way Hand Tied
 Seat Cush: SpringCell® Plus FibreSoft Wrap
 Back: Non-Sag Steel Sprung Back with Integrated Lumbar Support
 Back Cush: 100% FibreSoft Fill
 Cover: Leather or Fabric
 Legs: Timber
 Detailing: Twin Needle Stitching
 Seat & Back Cushions Zipped-In
 Options: Wide Selection of Moran Leathers & Fabrics
 Choice Of Timber Colours

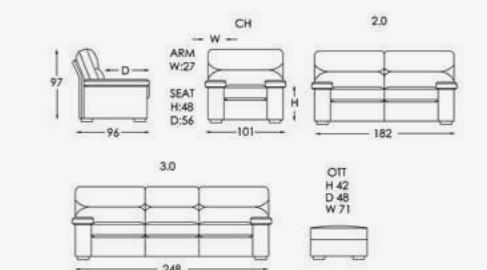

Salisbury 2-4 Seater Sofa

Frame: Kiln Dried Hardwood & Structural Composites
 Seat: 8 Way Hand Tied Steel Sprung Base & Edge
 Seat Cush: SpringCell® Plus FibreSoft Wrap
 Back: Webbed Back
 Back Cush: 100% FibreSoft Fill Loose Back Cushions OR 54x54cm Scatter Cushions 100% Feather Fill
 Cover: Fabric Only
 Legs: Glides
 Detailing: Self-Piping
 Single Pleated Valance
 Other: Standard 'Series B' Arm Caps
 Options: Wide Selection of Moran Fabrics
 Castors to Replace Glides

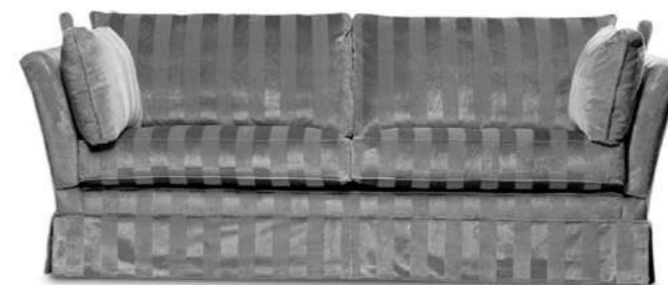
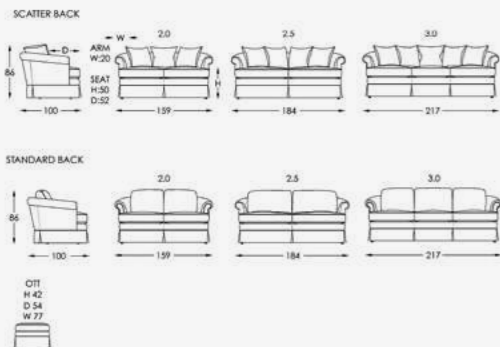

Knowle 2-4 Seater Sofa

Frame: Kiln Dried Hardwood & Structural Composites
 Seat: 8 Way Hand Tied Steel Sprung Base & Edge
 Seat Cush: SpringCell® Plus FibreSoft Wrap
 Back: Contemporary Non-Sag Steel Sprung Back
 Back Cush: Feather & Fibre Filled Loose Back Cushions
 Cover: Fabric Only
 Legs: Glides
 Detailing: Self-Piping
 Single Pleated Valance
 Tassels
 Feather & Fibre Filled Bolsters
 Arm Caps when in Fabric
 Options: Wide Selection of Moran Fabrics
 Castors to Replace Glides
 Fabric Protection

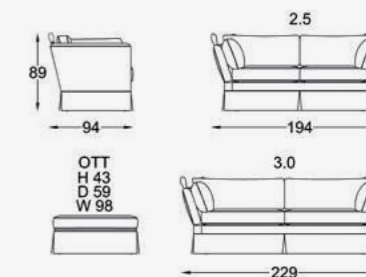

Claire 2-4 Seater Sofa

Frame: Kiln Dried Hardwood & Structural Composites
 Seat: Contemporary Non-Sag Steel Sprung Base
 Seat Cush: SpringCell® plus Feather Wrap
 Back: Contemporary Non-Sag Steel Sprung Back with Integrated Lumbar Support
 Back Cush: 100% FibreSoft Fill
 Cover: Leather or Fabric
 Legs: Timber with Brass Castor
 Detailing: Self Piping on Cushions
 Arm Pleating
 Other: Standard 'Series B' Arm Caps when in Fabric
 Straight Timber Leg without Castor
 Options: Wide Selection of Moran Leathers & Fabrics
 Choice of Timber Colours
 Foam plus Feather Wrap Seat Cushion

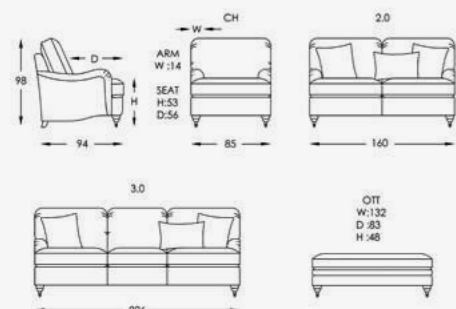

Maison II 2-4 Seater Sofa

Frame: Kiln Dried Hardwood & Structural Composites
 Seat: Contemporary Non-Sag Steel Sprung Base
 Seat Cush: SpringCell® Plus Feather Wrap Loose Cushions
 Back: Modern Webbed Back
 Back Cush: Feather and FibreSoft Fill Loose Cushions
 Cover: Fabric Only/ Loose Cover Only
 Legs: Glides
 Detailing: Self-Piping
 Other: Standard 'Series B' Arm Caps
 Options: Wide Selection of Moran Fabrics
 Castors to Replace Glides

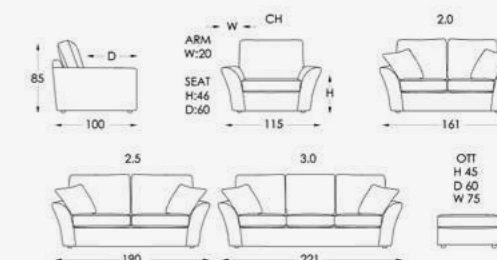

DAVID JONES EXCLUSIVE

DAVID JONES EXCLUSIVE

Woolwich 2-4 Seater Sofa

- Frame: Kiln Dried Hardwood & Structural Composites
- Seat: Contemporary Non-Sag Steel Sprung Front Edge
- Seat Cush: Feather Wrapped SpringCell® Seat Cushions
- Back: Contemporary Non-Sag Steel Sprung Back
- Back Cush: Feather & Fibre Zipped Back Cushions
- Cover: Leather or Fabric
- Legs: Timber
- Detailing: Hand Studded
- Other: Standard 'Series B' Arm Caps when in Fabric
- Options: Wide Selection of Moran Leathers & Fabrics
Fibre Wrapped SpringCell® Seat Cushions
Firmer SpringCell® Seat Cushion
Choice of Timber Colours
Fabric protection

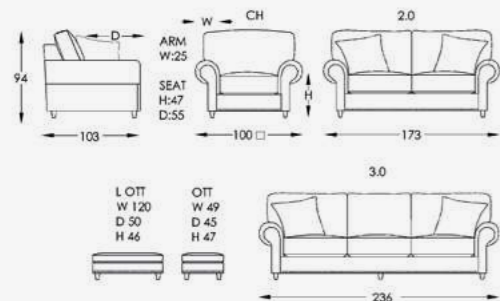

Alexis 2-4 Seater Sofa

- Frame: Kiln Dried Hardwood & Structural Composites
- Seat: Modern Webbed Base
- Seat Cush: Fully Upholstered SpringCell® Plus FibreSoft Wrap
- Back: Modern Webbed Base
- Back Cush: Fully Upholstered Foam & FibreSoft Wrap
- Cover: Fabric Only
- Legs: Timber Plinth
- Detailing: Self-Piping
- Other: Pleated Back
- Options: Wide Selection of Moran Fabrics
Choice of Timber Colours

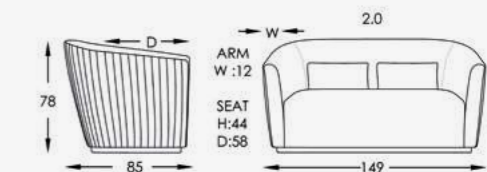

DAVID JONES EXCLUSIVE

Dartford 2-4 Seater Sofa

- Frame: Kiln Dried Hardwood & Structural Composites
- Seat: Contemporary Non-Sag Steel Sprung Base
- Seat Cush: SpringCell® Plus FibreSoft Wrap
- Back: Modern Webbed
- Back Cush: 100% FibreSoft Fill Fixed
- Cover: Leather or Fabric
- Legs: Timber
- Other: Standard 'Series B' Arm Caps when in Fabric
- Sleep Sys: Quilted Inner Spring Mattress:
Double (W) 131 cm x (L) 184cm x (D) 13cm
Queen (W) 151 cm x (L) 184cm x (D) 13cm
Counter Balanced Mechanism with TV headrest
- Options: Available as a Settee or Sofa Bed
Wide Selection of Moran Leathers & Fabrics
Choice of Timber Colours

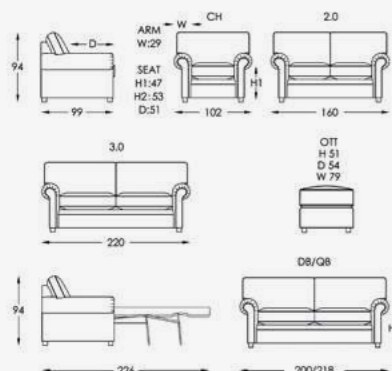

Marlin 2-4 Seater Sofa

- Frame: Kiln Dried Hardwood & Structural Composites
- Seat: 8 Way Hand Tied Fully Sprung Seat Base
- Seat Cush: SpringCell® Plus Feather Wrap
- Back: Contemporary Non-Sag Steel Sprung Back with Integrated Lumbar Support
- Back Cush: Feather & Fibre Fill
- Cover: Leather or Fabric
- Legs: Timber
- Detailing: Hand Studding along Arms & Front Plinth
Self-Piping on Cushion Edges
- Other: Luxurious Layer of extra Foam Padding on Arms
Seat & Back Cushions Zipped-In
Standard 'Series B' Arm Caps when in Fabric
- Options: Wide Selection of Moran Leathers & Fabrics
Choice of Timber Colours
Piping to Replace Hand Studding

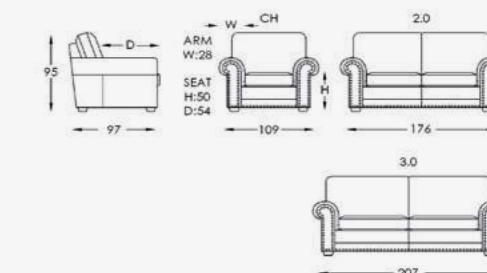

DAVID JONES EXCLUSIVE

Conrad 2-4 Seater Sofa

- Frame: Kiln Dried Hardwood & Structural Composites
- Seat: Contemporary Non-Sag Steel Sprung Base
- Seat Cush: SpringCell® Plus FibreSoft Wrap
- Back: Contemporary Non-Sag Steel Sprung Back with Integrated Lumbar Support (Sofa Bed: Modern Webbed Back)
- Back Cush: 100% FibreSoft Fill Loose
- Cover: Leather or Fabric
- Legs: Timber
- Detailing: Self Piping
- Other: Seat Cushions Harnessed in Sofa
Seat Cushions Loose in Sofa Bed
Seat Cushions Fully Upholstered in Push Back Recliner
- Sleep Sys: Quilted Inner Spring Mattress:
Double (W) 131 cm x (L) 184cm x (DJ) 13cm
Counter Balanced Mechanism with TV Headrest on DB Mechanism
- Options: Available as a Settee or Sofa Bed
Wide Selection of Moran Leathers & Fabrics
Choice of Timber Colours

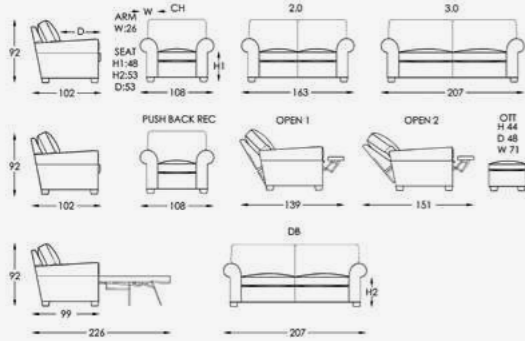

Brando 2-4 Seater Sofa

- Frame: Kiln Dried Hardwood & Structural Composites
- Seat: 8 Way Hand Tied Steel Sprung Base
Recliner: Contemporary Non-Sag Steel Sprung Mechanism
- Seat Cush: SpringCell® Plus FibreSoft Wrap Zipped-In
- Back: Contemporary Non-Sag Steel Sprung Back with Integrated Lumbar Support
- Back Cush: 100% FibreSoft Fill Zipped-In
Fully Upholstered on Push Back Recliner
- Cover: Leather or Fabric
- Legs: Timber
- Detailing: Self-Piping
Hand Studded Arms
- Other: Standard Series B Arm Caps when in Fabric
Wallsaver Push Back Recliner Chair available
120kg User Limit recommended on Recliner
Wide selection of Moran Leathers & Fabrics
Choice of Timber Colours
- Options: Piping to Replace Hand Studding

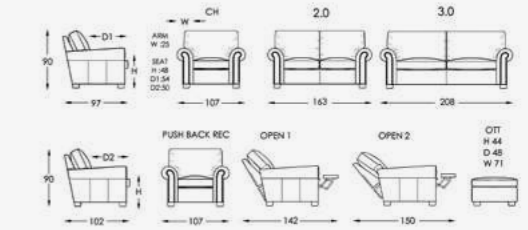

Dorchester 2-4 Seater Sofa

- Frame: Kiln Dried Hardwood & Structural Composites
- Seat: Contemporary Non-Sag Steel Sprung Base & Edge
- Seat Cush: SpringCell® Plus FibreSoft Wrap Zipped-In
- Back: Non-Sag Steel Sprung Back with Integrated Lumbar Support
- Back Cush: 100% FibreSoft Fill Zipped-In
- Cover: Leather or Fabric
- Legs: Timber
- Detailing: Twin Stitched Edges
Pleating Arm Detail
- Other: Hand studding with Burnished Antique Studs
Standard 'Series B' Arm Caps when in Fabric
- Options: Wide selection of Moran Leathers & Fabrics
Choice of Timber Colours

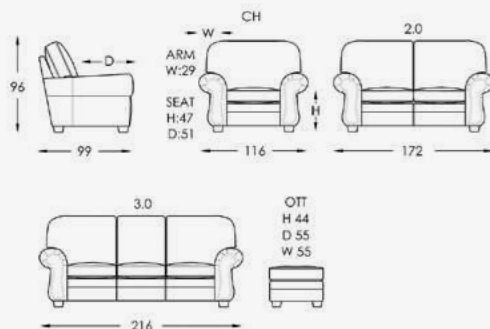

Harvard 2-4 Seater Sofa

- Frame: Kiln Dried Hardwood & Structural Composites
- Seat: Contemporary Non-Sag Steel Sprung Base
- Seat Cush: SpringCell® Plus Feather Wrap Zipped-In
- Back: Non-Sag Steel Sprung Back with Integrated Lumbar Support
- Back Cush: 100% FibreSoft Wrap Zipped-In
- Cover: Leather or Fabric
- Legs: Timber with Brass Castors
- Detailing: Self-Piping
Arm Pleating
- Other: Standard 'Series B' Arm Caps when in Fabric
- Options: Wide Selection of Moran Leathers & Fabrics
Straight Timber Leg without Castor
Choice of Timber Colours

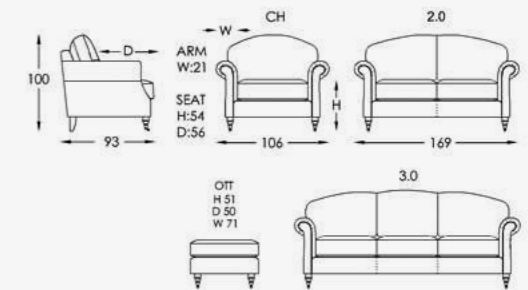



MORAN WELLINGTON SOFA
DISPLAYED IN: MORAN LEATHER & GLIDES
SHOWING: 3.0 SEAT SOFA

Cambridge

2-4 Seater Sofa

- Frame: Kiln Dried Hardwood & Structural Composites
- Seat: Contemporary Non-Sag Steel Sprung Base
- Seat Cush: SpringCell® Plus FibreSoft Wrap
- Back: Contemporary Non-Sag Steel Sprung Back
- Back Cush: Fully Upholstered Foam & FibreSoft wrap
- Cover: Leather Only
- Legs: Timber
- Detailing: Self-piped Hand Studding
- Options: Wide Selection of Moran Leathers
Choice of Timber Colours on legs

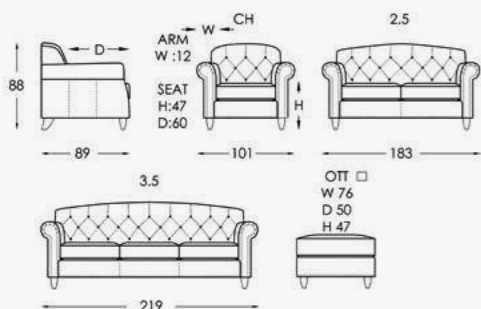

Bastille

2-4 Seater Sofa

- Frame: Kiln Dried Hardwood & Structural Composites
- Seat: Contemporary Non-Sag Steel Sprung Base
- Seat Cush: SpringCell® Plus Feather Wrap
- Back: Contemporary Non-Sag Steel Sprung Back
- Back Cush: Diamond Buttoned Fully Upholstered Foam & FibreSoft Wrap Fixed Back
- Cover: Leather or Fabric
- Legs: Timber
- Detailing: Hand-Tied Diamond Buttoning Hand-Studding Self-Piping
- Other: Zipped Seat Cushion in Leather
Loose Seat Cushions in Fabric
Fixed Back
- Options: Wide Selection of Moran Leathers & Fabrics
Piping to Replace Hand-Studding
Choice of Timber Colours

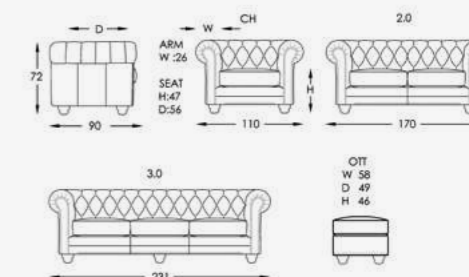

DAVID JONES EXCLUSIVE

Shelford

2-4 Seater Sofa

- Frame: Kiln Dried Hardwood & Structural Composites
- Seat: 8 Way Hand Tied Steel Sprung Base
- Seat Cush: SpringCell® Plus FibreSoft Wrap
- Back: Contemporary Non-Sag Steel Sprung Back
- Back Cush: Diamond Buttoned Styled Back
- Cover: Leather Only
- Legs: Timber
- Other: Hand Studding Detailing along Arm Face and Front Plinth
Seat Cushions Zipped-In
- Options: Wide Selection of Moran Leathers
SpringCell® Plus FeatherWrap Seat Cushion
Choice of Timber Colours on legs
Piping to Replace Hand Studding

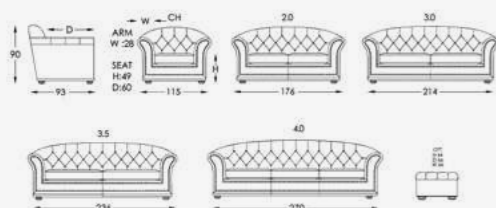

Chester

2-4 Seater Sofa

- Frame: Kiln Dried Hardwood & Structural Composites
- Seat: Contemporary Non-Sag Steel Sprung Base
- Seat Cush: SpringCell® Plus FibreSoft Wrap
- Back: Contemporary Non-Sag Steel Sprung Back
- Back Cush: Diamond Buttoned Fully Upholstered Back & Arms
- Cover: Leather Only
- Legs: Glides
- Detailing: Hand Studded Self-Piping
- Other: Seat Cushions Zipped-In
- Options: Wide Selection of Moran Leathers
Castors to Replace Glides

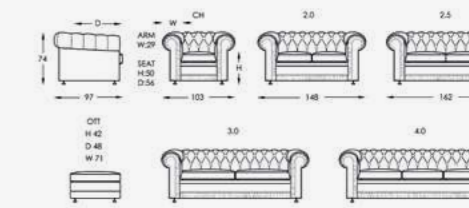

Merry Widow 2-4 Seater Sofa

- Frame: Kiln Dried Hardwood & Structural Composites
- Seat: Contemporary Non-Sag Steel Sprung Base
- Seat Cush: SpringCell® Plus FibreSoft Wrap Zipped-In
- Back: Contemporary Non-Sag Steel Sprung Back
- Back Cush: Diamond Buttoned Fully Upholstered Foam & FibreSoft Wrap Fixed Back
- Cover: Leather Only
- Legs: Glides with High Impact Surrounds
- Detailing: Hand Studding
Self Piping
Hand Tied Diamond Buttoning
- Other: Removable Zipped in Seat Cushions
- Options: Wide Selection of Moran Leathers
Timber Bun Feet
Choice of Timber Colours
Castors to Replace Glides

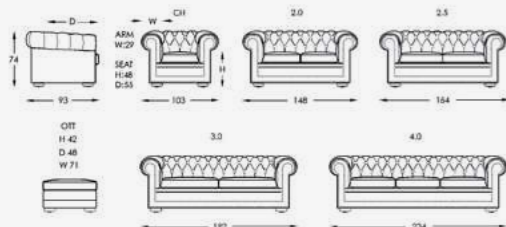

Hampshire 2-4 Seater Sofa

- Frame: Kiln Dried Hardwood & Structural Composites
- Seat: 8 Way Hand Tied
- Seat Cush: SpringCell® Plus FibreSoft Wrap Zipped-In
- Back: Contemporary Non-Sag Steel Sprung Back
- Back Cush: Diamond Buttoned Fully Upholstered Foam & FibreSoft Wrap Fixed Back
- Cover: Leather Only
- Legs: Glides with High Impact Surrounds
- Detailing: Hand-Studding
Self-Piping
Hand-Tied Diamond Buttoning
- Other: Removable Zipped-In Seat Cushions
- Options: Wide Selection of Moran Leathers
Castors with High Impact Surrounds
to Replace Glides

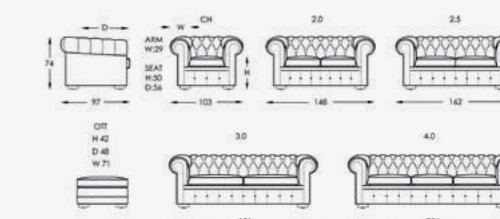

Wellington 2-4 Seater Sofa

- Frame: Kiln Dried Hardwood & Structural Composites
- Seat: Contemporary Non-Sag Steel Sprung Base
- Seat Cush: SpringCell® Plus FibreSoft Wrap Zipped-In
- Back: Contemporary Non-Sag Steel Sprung Back
- Back Cush: Diamond Buttoned Fully Upholstered Foam & FibreSoft Wrap
- Cover: Leather Only
- Legs: Glides with High Impact Surrounds
- Detailing: Self-Piping
Hand Studding
- Options: Wide Selection of Moran Leathers
Castors to Replace Glides

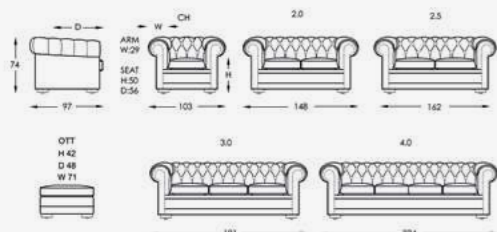

Mont Blanc 2-4 Seater Sofa

- Frame: Kiln Dried Hardwood & Structural Composites
- Seat: Contemporary Non-Sag Steel Sprung Base
- Seat Cush: SpringCell® Plus FibreSoft Wrap Zipped-In
- Back: Contemporary Non-Sag Steel Sprung Back
- Back Cush: Diamond Buttoned Fully Upholstered Foam & FibreSoft Wrap Fixed Back
- Cover: Leather or Fabric
- Legs: Glides with High Impact Surrounds
- Detailing: Self-Piping
Hand-Tied Diamond Buttoning
Vertical Panels with Blind Stitching across Front Base
- Other: Removable Zipped in Seat Cushions when in Leather
- Options: Wide Selection of Moran Leathers & Fabrics
Choice of Timber Colours
Castors to Replace Glides

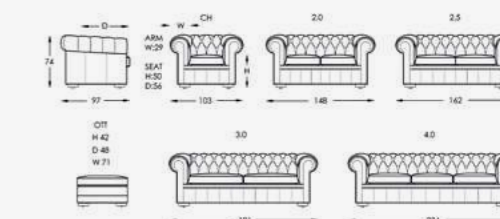

Spector 2-4 Seater Sofa

- Frame: Kiln Dried Hardwood & Structural Composites
- Seat: Contemporary Non-Sag Steel Sprung Base
- Seat Cush: SpringCell® Plus FibreSoft Wrap Zipped-In
- Back: Contemporary Non-Sag Steel Sprung Back
- Back Cush: Diamond Buttoned Fully Upholstered Foam & FibreSoft Wrap Fixed Back
- Cover: Leather Only
- Legs: Timber Bun Feet
- Detailing: Hand Studding
Self-Piping
Hand Tied Diamond Buttoning
- Other: Removable Zipped in Seat Cushions
- Options: Wide Selection of Moran Leathers
Choice of Timber Colours

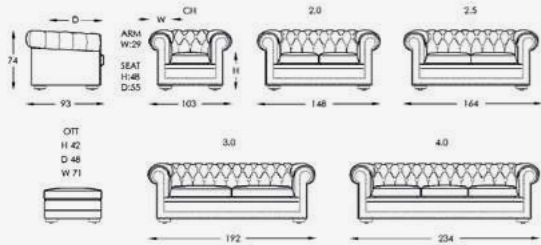

Benson 2-4 Seater

- Frame: Kiln Dried Hardwood & Structural Composites
- Seat: 8 Way Hand Tied Steel Sprung Base
- Recliner: Contemporary Non-Sag Steel Sprung Mechanism
- Seat Cush: SpringCell® Plus FibreSoft Wrap Zipped-In
- Back: Non-Sag Steel Sprung Back with Integrated Lumbar Support
- Recliner: Modern Webbed Back
- Back Cush: 100% FibreSoft Fill Zipped-In
- Cover: Leather or Fabric
- Legs: Timber on Fixed, Glides on Recliners
- Detailing: Self-Piping, Twin needle stitching
- Other: Upholstered Handle on Recliners
Neat Pop-up Mid-Ottoman on W/S Recliner
120kg user limit recommended on W/S Recliner
- Options: Wide Selection of Moran Leathers & Fabrics
Recliners available as Manual or Motorised
Recliner Control Options - Manual Handle, Finger Tip Release OR Motorised Dual Button on Motorised Model
Choice of Timber Colours on Fixed Model

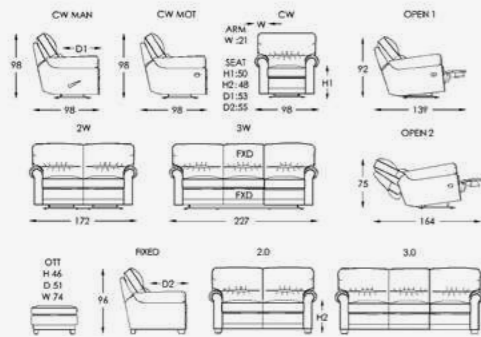

Malo Modular Sofa

- Frame: Kiln Dried Hardwood & Structural Composites
- Seat: Contemporary Non-Sag Steel Sprung Base
- Seat Cush: SpringCell® Plus Feather Wrap
- Back: Modern Webbed Back
- Back Cush: 100% FibreSoft Fill
- Cover: Fabric Only
- Legs: Rounded Timber
- Detailing: Top-Stitching
- Other: Removable Seat & Back Cushions
Matching Loose Scatter Cushions with Each Unit
Standard 'Series B' Arm Caps when in Fabric
- Options: Wide Selection of Moran Fabrics
LHF/RHF Chaise Configurations

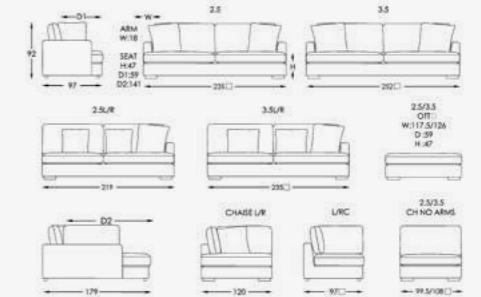

Ryde Modular Sofa

- Frame: Kiln Dried Hardwood & Structural Composites
- Seat: Contemporary Non-Sag Steel Sprung Base
- Seat Cush: SpringCell® Plus Feather Wrap
- Back: Modern Webbed Back
- Back Cush: Leather and FibreSoft Fill Cushion
- Cover: Leather or Fabric
- Legs: Timber
- Detailing: Top-Stitching
- Other: Modular Units for Flexible Configurations
Units with Lock-Together Crocodile Clips
- Options: Wide Selection of Moran Leathers & Fabrics
Choice of Timber Colours

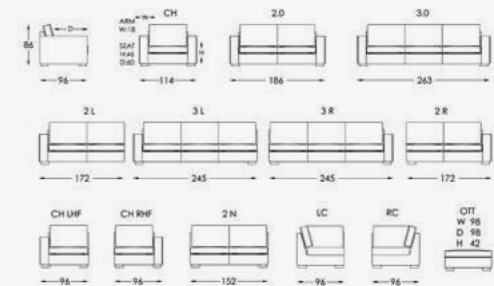

Connelly Modular Sofa

Frame: Kiln Dried Hardwood & Structural Composites
 Seat: 8 Way Hand Tied
 Seat Cush: SpringCell® Plus Feather Wrap
 Back: Modern Webbed Back
 Back Cush: 100% FibreSoft Wrap
 Cover: Leather or Fabric
 Legs: Timber Plinth
 Detailing: Top-Stitching
 Options: Wide Selection of Moran Leathers & Fabrics
 Choice of Timber Colours

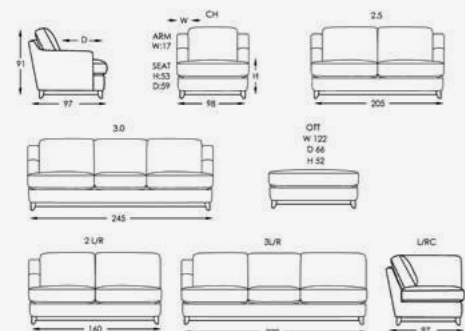

Albi Modular Sofa

Frame: Kiln Dried Hardwood & Structural Composites
 Seat: Contemporary Non-Sag Steel Sprung Base
 Seat Cush: SpringCell® Plus FibreSoft Wrap
 Back: Modern Webbed Back
 Back Cush: 100% FibreSoft Fill Fixed Back with Integrated Lumbar Cushioning and Adjustable Headrest
 Cover: Leather or Fabric
 Legs: Timber
 Detailing: Twin-Needle Stitching
 Other: Manually Adjustable Headrest with Chrome Fixtures
 Zipped-In Seat Cushions
 Options: Wide Selection of Moran Leathers & Fabrics
 LHF/RHF Chaise Configurations
 Choice of Timber Colours

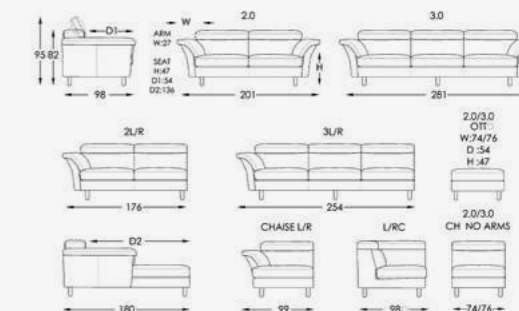

Pasadena Modular Sofa

Frame: Kiln Dried Hardwood & Structural Composites
 Seat: Contemporary Non-Sag Steel Sprung Base
 Seat Cush: SpringCell® Plus Feather Wrap Zipped-In Seat Cushion on Settee
 Fully Upholstered Seat Cushion on Chaise
 Back: Modern Webbed Back
 Back Cush: 100% FibreSoft Fill Back Cushions
 Cover: Leather or Fabric
 Legs: Timber
 Detailing: Self-Piping
 Options: Wide Selection of Moran Leathers & Fabrics
 Firmer SpringCell® Seat Cushions
 Choice of Timber Colours

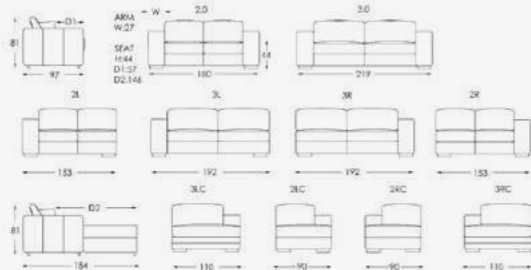

Ella Modular Sofa

Frame: Kiln Dried Hardwood & Structural Composites
 Seat: Contemporary Non-Sag Steel Sprung Base
 Seat Cush: SpringCell® Plus FibreSoft Wrap Zipped-In Cushion
 Back: Contemporary Non-Sag Steel Sprung Back
 Back Cush: 100% FibreSoft Fill Zipped-In
 Cover: Leather or Fabric
 Legs: Timber
 Detailing: Top-Stitching
 Other: Standard 'Series B' Arm Caps when in Fabric
 Options: Wide selection of Moran Leathers & Fabrics
 Choice of Timber Colours

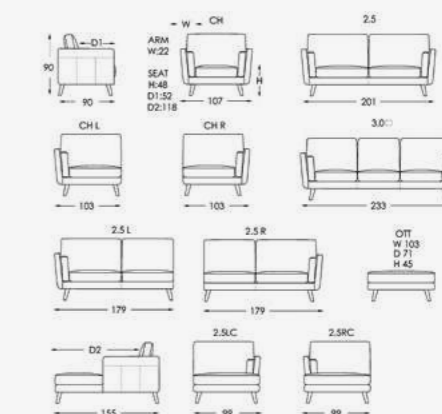

Newport Modular Sofa

Frame: Kiln Dried Hardwood & Structural Composites
 Seat: Contemporary Non-Sag Steel Sprung Base
 Seat Cush: SpringCell® Plus FibreSoft Wrap
 Back: Contemporary Non-Sag Steel Sprung Back with Integrated Lumbar Support
 Back Cush: 100% FibreSoft Fill Back Cushions
 Cover: Leather or Fabric
 Legs: Timber
 Detailing: Top-Stitching
 Options: Wide Selection of Moran Leathers & Fabrics
 Chaise can be either LHF or RHF

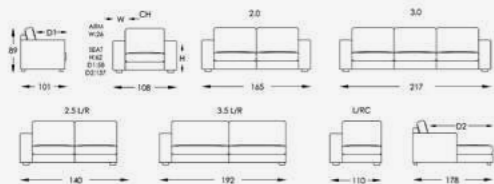

Nevada Theatre Suite

Frame: Kiln Dried Hardwood & Structural Composites
 Seat: Contemporary Non-Sag Steel Sprung Base
 Seat Cush: Foam and FibreSoft Wrap
 Back: Contemporary Non-Sag Steel Sprung Back with Integrated Lumbar Support
 Back Cush: Foam and FibreSoft Wrap
 Cover: Leather or Fabric
 Legs: Chrome Steel
 Detailing: Top-Stitching
 Options: Wide Selection of Moran Leathers & Fabrics
 Chaise can be either LHF or RHF

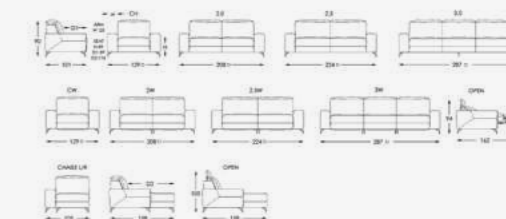

DAVID JONES EXCLUSIVE

Caroline Modular Sofa

Frame: Kiln Dried Hardwood & Structural Composites
 Seat: Contemporary Non-Sag Steel Sprung Base
 Seat Cush: SpringCell® Plus FibreSoft Wrap
 Back: Modern Webbed Back
 Back Cush: Feather & Fibre Wrap
 Cover: Leather Only
 Legs: Glides
 Detailing: Top-Stitching
 Hand Studding
 Options: Wide Selection of Moran Leathers

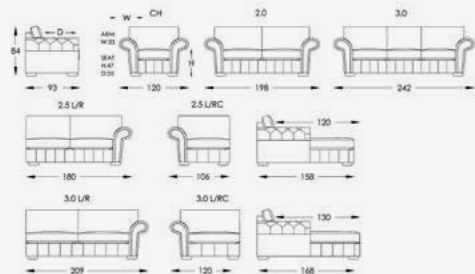

Triple Crown Theatre Suite

Frame: Kiln Dried Hardwood & Structural Composites
 Seat: Contemporary Non-Sag Steel Sprung Base
 Seat Cush: SpringCell® Plus FibreSoft Wrap
 Back: Contemporary Non-Sag Steel Sprung Back
 Back Cush: 100% FibreSoft Fill Waterfall Style
 Fixed Back Cushion
 Cover: Leather or Fabric
 Other: Upholstered RH Handle (Chair)
 Fingertip release (2.0S & 3.0S Recliner)
 Wrap Over Chaise
 Fully Upholstered Seat Cushions on Recliners
 Removable Seat Cushions on Fixed Settees
 Options: Wide selection of Moran Leathers & Fabrics
 Recliner Chairs as Manual, Motorised or Motorised with Lift Sofas as Manual, Motorised or Fixed
 Recliner Control Options (RH or LH) -
 Chair: Upholstered Manual Handle, Fingertip Release Trigger or Motorised Dual Button
 Sofas: Fingertip Release Trigger or Motorised Dual Button

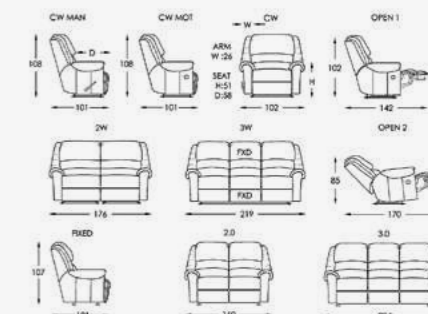

Pilot Theatre Suite

- Frame: Kiln Dried Hardwood & Structural Composites
- Seat: Contemporary Non-Sag Steel Sprung Base
- Seat Cush: SpringCell® Plus FibreSoft Wrap
- Back: Modern Webbed Back
- Back Cush: 100% FibreSoft Fill
- Cover: Leather or Fabric
- Legs: Glides
- Detailing: Top-Stitching
Padded Arm Rests
- Other: 120kg User Limit Recommended
RH Fingerlip Release as Standard
- Options: Wide Selection of Moran Leathers and Fabrics
Upholstered Handle to Replace FingerTip Release
LH Upholstered Handle or Finger Tip Release
Recliner Chairs as Manual, Motorised or Motorised with Lift
Sofas as Manual, Motorised or Fixed

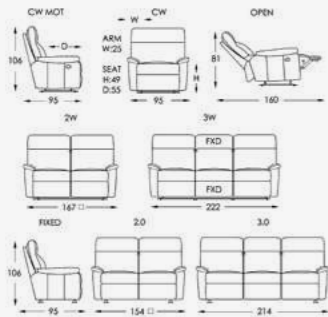

Sultan Theatre Suite

- Frame: Kiln Dried Hardwood & Structural Composites
- Seat: Contemporary Non-Sag Steel Sprung Base
- Seat Cush: SpringCell® Plus FibreSoft Wrap Fully Upholstered
- Back: Modern Webbed
- Back Cush: 100% FibreSoft Fill Fixed Back Cushions
- Cover: Leather or Fabric
- Other: 120kg User Limit Recommended
RH Fingerlip Release as Standard
- Options: Wide Selection of Moran Leathers and Fabrics
Upholstered Handle to Replace FingerTip Release
LH Upholstered Handle or Finger Tip Release
Recliner Chairs as Manual, Motorised or Motorised with Lift
Sofas as Manual, Motorised or Fixed

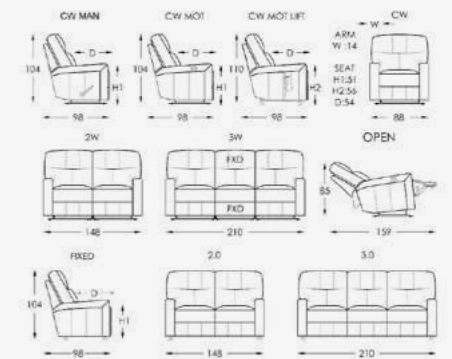

Atlantis Theatre Suite

- Frame: Kiln Dried Hardwood & Structural Composites
- Seat: Contemporary Non-Sag Steel Sprung Base
- Seat Cush: SpringCell® Plus FibreSoft Wrap
- Back: Modern Webbed Back
- Back Cush: 100% FibreSoft Fill Fixed Cushions
- Cover: Leather or Fabric
- Detailing: Wrap-Over Chaise
Padded Arm Rests
Tailored Stitching Lines
Slim Modern Design
- Other: 120kg User Limit Recommended
RH Fingerlip Release as Standard
- Options: Wide Selection of Moran Leathers and Fabrics
Upholstered Handle to Replace FingerTip Release
LH Upholstered Handle or Finger Tip Release
Recliner Chairs as Manual, Motorised or Motorised with Lift
Sofas as Manual, Motorised or Fixed

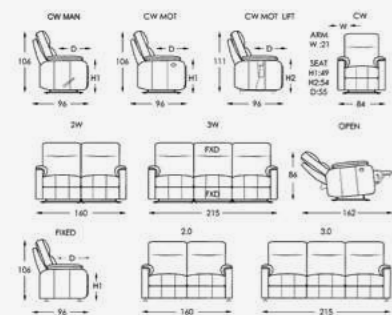

Cloud Theatre Suite

- Frame: Kiln Dried Hardwood & Structural Composites
- Seat: Contemporary Non-Sag Steel Sprung Base
- Seat Cush: SpringCell® Plus FibreSoft Wrap Fully Upholstered
- Back: Contemporary Non-Sag Steel Sprung Back with Integrated Lumbar Support
- Back Cush: FibreSoft Fill & Foam Core Waterfall Style
- Cover: Leather or Fabric
- Legs: Glides
- Detailing: Twin Needle Stitching
Wrap-Over Chaise
Padded Arm Rests
Upholstered RH Handle on Chair as Standard
Finger Tip Release on 2.0S & 3.0S as Standard
Standard Series B Arm Caps when in Fabric
- Other: 120kg User Limit Recommended
- Options: Wide selection of Moran Leathers & Fabrics
Recliner Chairs as Manual, Motorised or Motorised with Lift
Recliner Sofas as Manual, Motorised, Fixed
LH Upholstered Handle or FingerTip Release

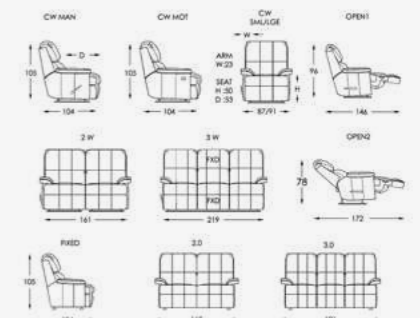



MORAN BRUBECK - SOFA BED
DISPLAYED IN: MORAN FABRIC & TIMBER LEGS
SHOWING: SOFA BED
DAVID JONES EXCLUSIVE

Savannah 2-4 Seater Sofa Bed

- Frame: Kiln Dried Hardwood & Structural Composites
- Seat: 8 Way Hand Tied (Sofa Only)
- Seat Cush: SpringCell® Plus FibreSoft Wrap Loose
- Back: Modern Webbed Back
- Back Cush: 100% FibreSoft Wrap Zipped-In
- Cover: Leather or Fabric
- Legs: Chrome Steel
- Detailing: Top-Stitching
- Wide Sleigh Like Arm with Curved Back End
- Sleep Sys: Quilted Inner Spring Mattress
- Double (W) 132cm x (L) 184cm x (D) 13cm
- Queen (W) 152cm x (L) 184cm x (D) 13cm
- Counter Balanced Mechanism
- TV Headrest on DB & QB Mechanism
- Other: Standard 'Series B' Arm Caps when in Fabric
- Options: Available as a Settee or Sofabed
- Wide Selection of Moran Fabrics & Leathers

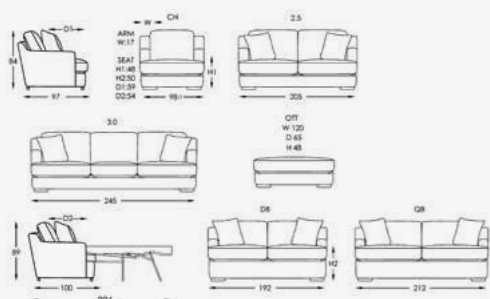

DAVID JONES EXCLUSIVE



DAVID JONES EXCLUSIVE

Brubeck Sofa Bed

- Frame: Kiln Dried Hardwood & Structural Composites
- Seat: Contemporary Non-Sag Steel Sprung Base (Sofa Only)
- Seat Cush: SpringCell® Plus FibreSoft Wrap
- Back: Contemporary Non-Sag Steel Sprung Back (Modern Webbed Back on Sofa bed)
- Back Cush: 100% FibreSoft Filled Zipped-In Cushions
- Cover: Leather or Fabric
- Legs: Timber
- Detailing: Top-Stitching
- Sleep Sys: Quilted Inner Spring Mattress
- Single (W) 92cm x (L) 184cm x (D) 13cm
- King Single (W) 102cm x (L) 184cm x (D) 13cm
- Double (W) 132cm x (L) 184cm x (D) 13cm
- Queen (W) 152cm x (L) 184cm x (D) 13cm
- Counter Balanced Mechanism
- Seat Cushions Harnessed on Settee, Loose on Sofa Bed
- Options: Available as a Settee or Sofa Bed
- Wide Selection of Moran Leathers & Fabrics
- Choice of Timber Colours

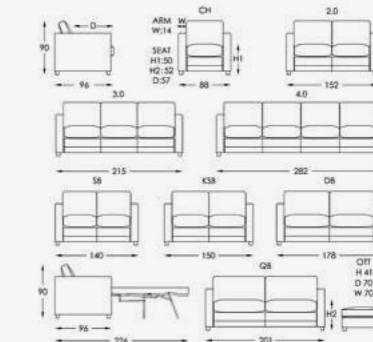

Harry Sofa Bed

- Frame: Kiln Dried Hardwood & Structural Composites
- Seat: Contemporary Non-Sag Steel Sprung Base (Sofa Only)
- Seat Cush: SpringCell® Plus FibreSoft Wrap
- Back: Modern Webbed Back
- Back Cush: 100% FibreSoft Fill
- Loose Back Cushions
- Cover: Leather or Fabric
- Legs: Timber
- Detailing: Self-Piping
- Other: Removable Seat & Back Cushions
- Standard 'Series B' Arm Caps when in Fabric
- Options: Wide Selection of Moran & Fabrics
- Choice of Timber Colours
- Mattress: Active Comfort Reversible Mattress
- Mattress Size: Double 183 x 132cm
- Mechanism: Counter Balanced Mechanism with TV Headrest

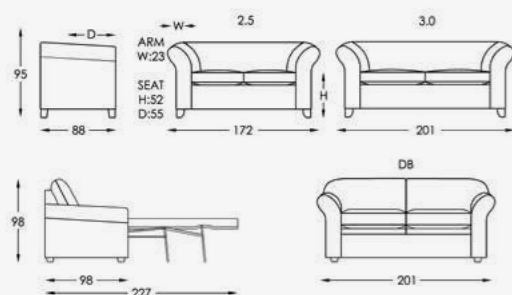

Baxter Sofa Bed

- Frame: Kiln Dried Hardwood & Structural Composites
- Seat: Contemporary Non-Sag Steel Sprung Base
- Seat Cush: SpringCell® Plus FibreSoft Wrap
- Back: Contemporary Non-Sag Steel Sprung Back (Sofa Bed: Modern Webbed Back)
- Back Cush: 100% FibreSoft Fill Loose
- Cover: Leather or Fabric
- Legs: Timber
- Detailing: Self-Piping
- Sleep Sys: Quilted Inner Spring Mattress
- Double (W) 132cm x (L) 184cm x (D) 13cm
- Counter Balanced Mechanism
- TV Headrest on DB Mechanism
- Other: Standard 'Series B' Arm Caps when in Fabric
- Seat Cushions Harnessed on Settee, Loose on Sofa Bed
- Options: Available as a Settee or Sofa Bed
- Wide Selection of Moran Leathers & Fabrics
- Choice of Timber Colours

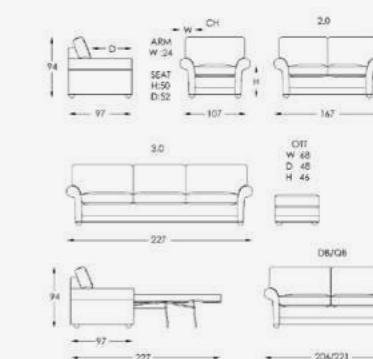

Pandora Bedhead

- Frame: Kiln Dried Hardwood, Structural Composites & Plywood
- Fabrication: Fully Upholstered Foam & FibreSoft Fill
- Cover: Leather or Fabric
- Legs: Turned Timber
- Detailing: Diamond Buttoned Feature across Back
Curved rolling feature top
- Options: Wide Selection of Moran Leathers & Fabrics
Choice of Timber Colours

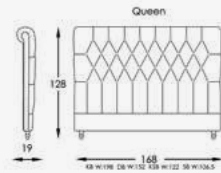

DAVID JONES EXCLUSIVE



Jalen Bedhead

- Frame: Kiln Dried Hardwood, Structural Composites & Plywood
- Fabrication: Fully Upholstered Foam & FibreSoft Fill
- Cover: Leather or Fabric
- Legs: Timber
- Detailing: Diamond Buttoned Headboard Design
Self-Piped Border
- Options: Wide Selection of Moran Leathers & Fabrics
Choice of Timber Colours

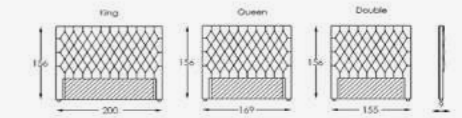

Lombard Bedhead

- Frame: Kiln Dried Hardwood, Structural Composites & Plywood
- Fabrication: Fully Upholstered Foam & FibreSoft Fill
- Cover: Leather or Fabric
- Legs: Turned Timber
- Detailing: Diamond Buttoned Feature across Back
- Options: Wide Selection of Moran Leathers & Fabrics
Choice of Timber Colours

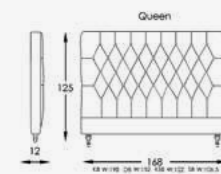

Axel Bedhead

- Frame: Kiln Dried Hardwood, Structural Composites & Plywood
- Fabrication: Fully Upholstered Foam & FibreSoft Fill
- Cover: Leather or Fabric
- Legs: Timber
- Detailing: Exposed Timber Surround
Twin-Needle Stitching
- Options: Wide Selection of Moran Leathers & Fabrics
Choice of Timber Colours

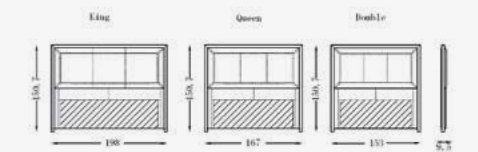

Princess Bedhead

- Frame: Kiln Dried Hardwood, Structural Composites & Plywood
- Fabrication: Foam & FibreSoft
- Back: Diamond Buttoning Feature across Back
- Cover: Fully Upholstered Fabric Only
- Legs: Turned Bun Timber
- Detailing: Hand Studding Detail around frame
- Options: Choice of Timber Colours
Encasements with Slats

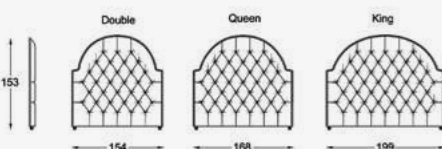

DAVID JONES EXCLUSIVE



Pellier Bedhead

- Frame: Kiln Dried Hardwood, Structural Composites & Plywood
- Fabrication: Foam & FibreSoft Fill
- Cover: Fully Upholstered Fabric Only
- Legs: Timber
- Detailing: Hand Studded Border
- Options: Wide Selection of Moran Fabrics
Choice of Timber Colours

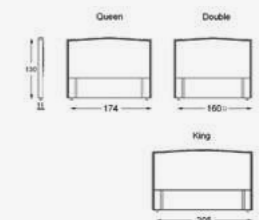



MORAN NOVA - BED SET
DISPLAYED IN: MORAN LEATHER & TIMBER LEGS
SHOWING: BEADHEAD, SIDE TABLES & LONG BENCH
DAVID JONES EXCLUSIVE

Imperial Bedhead

Frame: Kiln Dried Hardwood, Structural Composites & Plywood
 Fabrication: Foam & FibreSoft
 Cover: Fully Upholstered Fabric Only
 Legs: Timber
 Options: Choice of Timber Colours

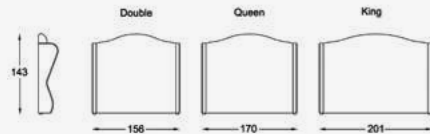

Valentine Bedhead

Frame: Kiln Dried Hardwood, Structural Composites & Plywood
 Fabrication: Fully Upholstered with Foam & FibreSoft Fill
 Cover: Fabric Only
 Legs: Timber
 Detailing: Blind Buttoned Headboard Design
 Options: Wide Selection of Moran Fabrics
 Choice of Timber Colours

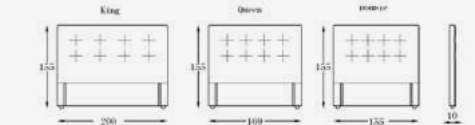

Lincoln Accent Chair

Frame: Kiln Dried Hardwood, Structural Composites & Plywood
 Fabrication: Fully Upholstered Foam & FibreSoft Fill
 Cover: Leather or Fabric
 Legs: Timber
 Detailing: Exposed Timber Side Feature Panel
 Options: Wide Selection of Moran Leathers & Fabrics
 Choice of Timber Colours
 Available as Bedhead only OR Bedhead + Encasement Choice of Timber Colours

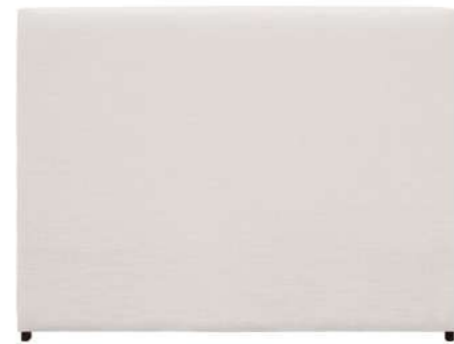
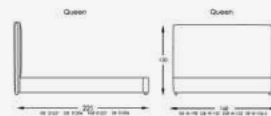

Dutchess Bedhead

Frame: Kiln Dried Hardwood, Structural Composites & Plywood
 Fabrication: Foam & FibreSoft
 Cover: Fully Upholstered Fabric Only
 Legs: Timber
 Detailing: Contrasting Twin Button Feature
 Contrast Piping
 Options: Choice of Timber Colours

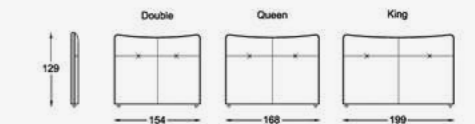

Mira Bedhead

Frame: Kiln Dried Hardwood, Structural Composites & Plywood
 Fabrication: Fully Upholstered Foam & FibreSoft Fill
 Cover: Leather or Fabric
 Legs: Timber
 Detailing: Self Piping on Edge of Headboard
 Self Piping on Inside Border
 Options: Wide Selection of Moran Leathers & Fabrics
 Choice of Timber Colours
 Available as Bedhead Only OR Bedhead + Encasement

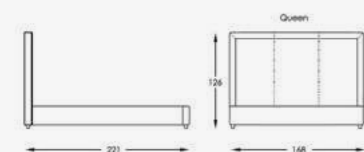

Kennedy Bedhead

Frame: Kiln Dried Hardwood, Structural Composites & Plywood
 Fabrication: Fully Upholstered Foam & FibreSoft Fill
 Cover: Leather or Fabric
 Legs: Timber
 Detailing: Narrow Padded Vertical Panels with Blind Stitching
 Self Piping on Frame Edges
 Options: Wide Selection of Moran Leathers & Fabrics
 Choice of Timber Colours

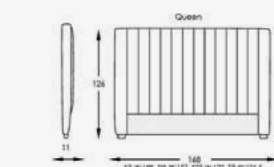

DAVID JONES EXCLUSIVE

Fremont Bedhead

Frame: Kiln Dried Hardwood, Structural Composites & Plywood
 Fabrication: Fully Upholstered Foam & FibreSoft Fill
 Cover: Leather or Fabric
 Legs: Timber
 Detailing: Blind Stitched Rectangular Grid Headboard
 Options: Wide Selection of Moran Leathers & Fabrics
 Choice of Timber Colours

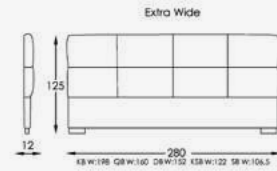

Zuar Accent Chair

Frame: Kiln Dried Hardwood, Structural Composites & Plywood
 Fabrication: Fully Upholstered Foam & FibreSoft Fill
 Cover: Leather Only
 Legs: Timber Plinth
 Detailing: Blind Stitched Waterfall Headboard Design
 Options: Wide Selection of Moran Leathers
 Choice of Timber Colours

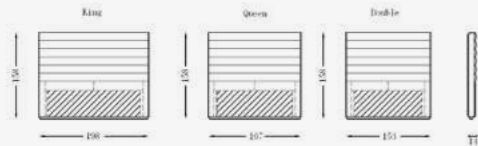

Emmerson Bedhead

Frame: Kiln Dried Hardwood, Structural Composites & Plywood
 Fabrication: Fully Upholstered Foam & FibreSoft Fill
 Cover: Leather or Fabric
 Legs: Timber
 Detailing: Self Piping on Edge of Headboard
 Self Piping on Inside Border
 Options: Wide Selection of Moran Leathers & Fabrics
 Choice of Timber Colours



MORAN ALEXIS - SOFA SUITE
 DISPLAYED IN: MORAN FABRIC & TIMBER PLINTH
 SHOWING: 2 SEATER SOFA, CHAIR & OTTOMAN
 DAVID JONES EXCLUSIVE

Ryde Coffee Table Ottoman

Frame: Kiln Dried Hardwood & Structural Composites
 Seat Cush: SpringCell® Plus Feather Wrap
 Cover: Leather or Fabric
 Legs: Timber
 Detailing: Top Stitching
 Options: Wide Selection of Moran Leathers & Fabrics
 Choice of Timber Colours



OTT
 W 98
 D 98
 H 42



DAVID JONES EXCLUSIVE

Maison Coffee Table Ottoman

Frame: Kiln Dried Hardwood & Structural Composites
 Seat: Contemporary Non-Sag Steel Sprung Base
 Seat Cush: Foam Plus Feather Wrap
 Cover: Fabric Only
 Legs: Glides
 Detailing: Removable Fabric Loose Slip Cover
 Self-Piping
 Options: Wide Selection of Moran Fabrics
 Additional Loose Slip Covers for Purchase



OTT
 H 45
 D 60
 W 75



Alaska Coffee Table Ottoman

Frame: Kiln Dried Hardwood & Structural Composites
 Seat Cush: High Resilience Foam & FibreSoft Wrap
 Fully Upholstered Diamond Buttoned Fixed Top
 Cover: Leather or Fabric
 Legs: Timber Plinth
 Detailing: Hand Tied Diamond Buttoning
 Options: Wide Selection of Moran Leathers & Fabrics
 Choice of Timber Colours on Plinth



OTT
 H 43
 D 62
 W 122



DAVID JONES EXCLUSIVE

Westwood Coffee Table Ottoman

Frame: Kiln Dried Hardwood & Structural Composites
 Seat: Contemporary Non-Sag Steel Sprung Base
 Seat Cush: Feather and FibreSoft Fill
 Cover: Fabric Only
 Legs: Glides
 Detailing: Self-Piping
 Hand Sewn Single Pleated Valance
 Options: Wide Selection of Moran Fabrics



OTT
 H 45
 D 52
 W 77



OTT
 H 48
 D 75
 W 132

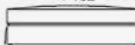

DAVID JONES EXCLUSIVE

Chess Coffee Table Ottoman

Frame: Kiln Dried Hardwood & Structural Composites
 Seat Cush: High Resilience Foam & FibreSoft Wrap
 Fully Upholstered Diamond Buttoned Fixed Top
 Cover: Leather or Fabric
 Legs: Timber
 Detailing: Diamond Buttoning
 Options: Wide Selection of Moran Leathers & Fabrics
 Choice of Timber Colours



OTT
 W 93
 D 93
 H 40



DAVID JONES EXCLUSIVE

Alexis Coffee Table Ottoman

Frame: Kiln Dried Hardwood & Structural Composites
 Seat: Modern Webbed Base
 Seat Cush: Fully Upholstered Foam & FibreSoft Wrap
 Cover: Fabric Only
 Legs: Timber Plinth
 Detailing: Self-Piping
 Pleating Technique on the Outside
 Options: Wide Selection of Moran Fabrics
 Choice of Timber Colours



OTT
 W 120
 D 55
 H 45



Claire Coffee Table Ottoman

Frame: Kiln Dried Hardwood & Structural Composites
 Seat: Contemporary Non-Sag Steel Sprung Base
 Seat Cush: SpringCell® Plus Feather Wrap
 Cover: Leather or Fabric
 Legs: Timber with Brass Castor
 Detailing: Self-Piping
 Options: Wide Selection of Moran Leathers and Fabrics
 Choice of Timber Colours



OTT
 W:132
 D :83
 H :48

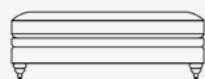

DAVID JONES EXCLUSIVE

Aero Coffee Table Ottoman

Frame: Kiln Dried Hardwood & Structural Composites
 Seat: Contemporary Non-Sag Steel Sprung Base
 Seat Cush: SpringCell® Plus FibreSoft Wrap
 Cover: Leather or Fabric
 Legs: Timber
 Detailing: Top Stitching
 Options: Wide Selection of Moran Leathers and Fabrics
 Choice of Timber Colours



OTT
 W 73
 D 73
 H 43



Elwood Coffee Table Ottoman

Frame: Kiln Dried Hardwood & Structural Composites
 Seat: Contemporary Non-Sag Steel Sprung Base
 Seat Cush: SpringCell® Plus FibreSoft Wrap
 Cover: Leather or Fabric
 Legs: Timber
 Detailing: Top Stitching
 Options: Wide Selection of Moran Leathers and Fabrics
 Choice of Timber Colours



OTT
 H 44
 D 54
 W 92

OTT
 H 44
 D 54
 W 122



DAVID JONES EXCLUSIVE

Norton Coffee Table Ottoman

Frame: Kiln Dried Hardwood & Structural Composites
 Seat: Contemporary Non-Sag Steel Sprung Base
 Seat Cush: SpringCell® Plus FibreSoft Wrap
 Cover: Leather or Fabric
 Legs: Steel
 Detailing: Top Stitching
 Options: Wide Selection of Moran Leathers and Fabrics
 Timber Legs



OTT
 H 44
 D 63
 W 88

L HIGH OTT
 H 42
 D 57
 W 122



Talia Coffee Table Ottoman

Frame: Kiln Dried Hardwood & Structural Composites
 Seat: Contemporary Non-Sag Steel Sprung Base
 Seat Cush: SpringCell® Plus Feather Wrap
 Cover: Leather or Fabric
 Legs: Timber
 Detailing: Top Stitching
 Options: Wide Selection of Moran Leathers and Fabrics
 Choice of Timber Colours



OTT
 W:130
 D :81
 H :44

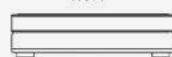

DAVID JONES EXCLUSIVE

Nova Side Table

Frame: Kiln Dried Hardwood & Structural Composites
 Fabrication: Fully Upholstered Foam & FibreSoft Fill
 Cover: Leather or Fabric
 Legs: Timber Plinth
 Detailing: Hand Studded Border around Base
 Framed Leg in Diagonal Grid Formation
 Options: Wide Selection of Moran Leathers & Fabrics
 Choice of Timber Colours
 Glass Top option available

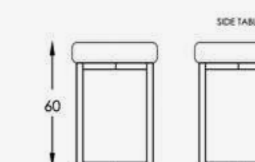

Nova Long Bench

Frame: Kiln Dried Hardwood & Structural Composites
 Fabrication: Fully Upholstered Foam & FibreSoft Fill
 Cover: Leather or Fabric
 Legs: Timber Plinth
 Detailing: Inset Stitched Frame Detail on Cushion Top
 Hand Studded Border around Base
 Self Piped Cushion Edge
 Framed Leg in Diagonal Grid Formation
 Options: Wide Selection of Moran Leathers & Fabrics
 Choice of Timber Colours

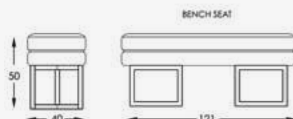

DAVID JONES EXCLUSIVE

Fremont Long Bench

Frame: Kiln Dried Hardwood & Structural Composites
 Fabrication: Fully Upholstered Foam & FibreSoft Fill
 Cover: Leather or Fabric
 Legs: Turned Timber
 Detailing: Diamond Buttoned Feature Cushion Top
 Options: Wide Selection of Moran Leathers & Fabrics
 Choice of Timber Colours



Altair Long Bench

Frame: Kiln Dried Hardwood & Structural Composites
 Fabrication: Fully Upholstered Foam & FibreSoft Fill
 Cover: Leather or Fabric
 Legs: Turned Timber
 Detailing: Blind Stitched Square Grid Design
 Square Framed Leg in Cross Grid Formation
 Options: Wide Selection of Moran Leathers & Fabrics
 Choice of Timber Colours

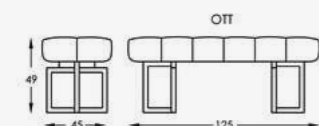

DAVID JONES EXCLUSIVE

DAVID JONES EXCLUSIVE

Pandora Storage Ottoman

Frame: Kiln Dried Hardwood & Structural Composites & Plywood
 Fabrication: Fully Upholstered Foam & FibreSoft Fill
 Cover: Leather or Fabric
 Legs: Turned Timber
 Detailing: Diamond Buttoned Feature Cushion Top
 Self Piped Cushion Edge
 Air Hinge Opening with Roomy Storage Area
 Options: Wide Selection of Moran Leathers & Fabrics
 Choice of Timber Colours

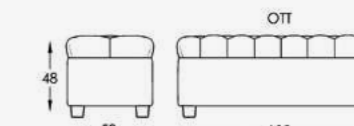

Pandora Long Bench

Frame: Kiln Dried Hardwood & Structural Composites
 Fabrication: Fully Upholstered Foam & FibreSoft Fill
 Cover: Leather or Fabric
 Legs: Turned Timber
 Detailing: Diamond Buttoned Feature Cushion Top
 Self Piped Cushion Edge
 Options: Wide Selection of Moran Leathers & Fabrics
 Choice of Timber Colours

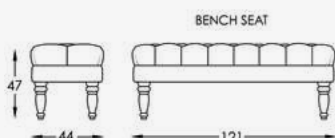

DAVID JONES EXCLUSIVE



DAVID JONES EXCLUSIVE

Brubeck Storage Ottoman

Frame: Kiln Dried Hardwood & Structural Composites & Plywood
 Fabrication: Fully Upholstered Foam & FibreSoft Fill
 Cover: Leather or Fabric
 Legs: Timber
 Detailing: Self Piped Cushion Edge
 Air Hinge Opening with Roomy Storage Area
 Options: Wide Selection of Moran Leathers & Fabrics
 Choice of Timber Colours

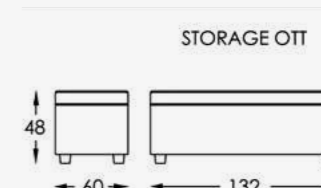

ACCENT CHAIRS

Aero	23
Alberta	24
Alicia	24
Boston	26
Bugatti	25
Carter	23
Celeste	25
Daniela	22
Jimmy	22
Juno	26
Monet	23
Professor	26
Romsey	27
Salon	24
Shelford Tub	25
Society	22

RECLINERS

Abbey	27
Admiral	30
Cloud	29
Olympus	29
Pilot	29
Spoillette	30
Sultan	28
Triple Crown W/Chaise	30

ACTIVE COMFORT

Cozy	31
Fusion	31
Grand	31
Jetty	31
Langham	31
Magnet	31
Maitland	31
Mia	31
Raleigh	31
Voyager	31

SOFA CHAIRS

Alexis	34
Claire	34
Elwood	32
Maison	33
Marlin	35
Oliver	33
Olsen	32
Sienna	32
Wellington	35
York	33

2-4 SEATER SOFAS

Alexis	51
Avondale	47
Bastille	57
Benson	60
Brando	53

2-4 SEATER SOFAS

Britney	46
Brooklyn	43
Brubeck	43
Burgess	42
Cambridge	56
Carlo	46
Casino	47
Chester	57
Claire	48
Conrad	52
Dartford	50
Dorchester	52
Elwood	40
Hampshire	59
Harvard	53
Knowle	49
Maison II	49
Marlin	51
Merry Widow	58
Mika	39
Mont Blanc	59
Norton	38
Omaha	38
Ontario	39
Oslo	42
Renoir	44-45
Salisbury	48
Shelford	56
Sienna	40
Spector	60
Talia	41
Thomas	41
Wellington	58
Woolwich	50
York	36-37

MODULAR SOFAS

Albi	63
Caroline	64
Connelly	62
Ella	63
Malo	61
Newport	64
Pasadena	62
Ryde	61

THEATRE SUITES

Atlantis	66
Cloud	67
Nevada	65
Pilot	66
Sultan	67
Triple Crown	65

SOFABEDS

Baxter	71
Brubeck	71
Harry	70
Savannah	70

BEDHEADS

Axel	73
Dutchess	77
Emmerson	78
Fremont	78
Imperial	76
Jalen	73
Kennedy	77
Lincoln	76
Lombard	72
Mira	76
Nova	74-75
Pandora	72
Pellier	73
Princess	72
Valentine	77
Zuar	78

COFFEE TABLE OTTOMANS

Aero	83
Alaska	80
Alexis	81
Chess	80
Claire	82
Elwood	82
Maison	81
Norton	83
Ryde	80
Talia	82
Westwood	81

SIDE TABLE

Nova	83
------	----

LONG BENCH

Altair	84
Fremont	85
Nova	84
Pandora	84

LONG BENCH

Brubeck	85
Pandora	85

O U R S E R V I C E S

You sit in it, we stand by it.

Our Melbourne based Sales and Aftersales team is here to help you every step of the way.

Our Sales team can look after you throughout your selection and ordering process and can offer you the best advice on caring for your furniture.

Our Aftersales department will look after your investment in comfort from the day of delivery should the need arise.

A ten-year frame warranty from date of purchase applies to each new order.

Moran also provides the option of replacing the Seat and Back "Inserts" in the models that have zippered removable covers. This is an added benefit to the consumer as the furniture never needs to be replaced just rejuvenated. The springcell seat and fibrefill back inserts can be replaced to return your furniture to its original standard of comfort and support, other seat and back options can also be ordered.

All replacement inserts carry a 5 year warranty.

Please log on to our website www.moranfurniture.com.au for further details on this service or contact our After Sales Department on **03 9590 4800**.





MORAN PANDORA - BED SET
DISPLAYED IN: MORAN FABRIC & TURNED TIMBER LEGS
SHOWING: BEDHEAD, LONG BENCH & CELESTE CHAIR
DAVID JONES EXCLUSIVE



MORAN
FURNITURE

Head Office

151-155 Woodlands Drive, Braeside VIC 3195

Showroom

18 Fairchild Street, Heatherton VIC 3205
(By Appointment Only)

GET IN TOUCH WITH US

Phone: +61 3 9590 4800 | 1300 786 222

Fax: +61 3 9590 4899

Email: info1@moranfurniture.com.au

Website: www.moranfurniture.com.au

FOLLOW US ON SOCIAL MEDIA



@moranfurnitureaustralia